

# TURBO-CHOPPER

from



MODEL

## TURBO-CHOPPER

The all new Turbo-Chopper from Great Plains combines our aggressive Turbo Blades with the action of a turbo patterned chopper reel. This allows for a “crisscross” pattern for chopping residue and working the soil while still maintaining the benefits of vertical tillage. This unit offers the versatility of a fall tillage tool combined with its use as a spring tillage unit for seedbed preparation. The “crisscross” pattern of this unit allows for the loosening and removal of root balls. The Turbo coulters are 20” in diameter with 10” spacing followed by the 18” diameter chopper reels. Both gangs of coulters and chopper reels are mounted on heavy 3” C-shanks with rubber cushioned cast bearings. The 18” chopper reels consist of six 4 1/2 inch high carbon steel blades. The unique spiral design allows constant contact with the soil to maximize cutting and reducing the vibration experienced with competitive reels. The chopper reels work perpendicular to the Turbo coulters providing a smooth seedbed for your planter. Our patented rolling harrow and reel combination is the recommended rear attachment for the ultimate seedbed for your planter.

### TURBO CHOPPER REEL



The turbo design allows the blades to attack the residue vertically, providing improved cutting, penetration, and decreased hairpinning.

### TILLAGE PASS

#### Turbo Coulters Gangs

#### Turbo Chopper Gangs

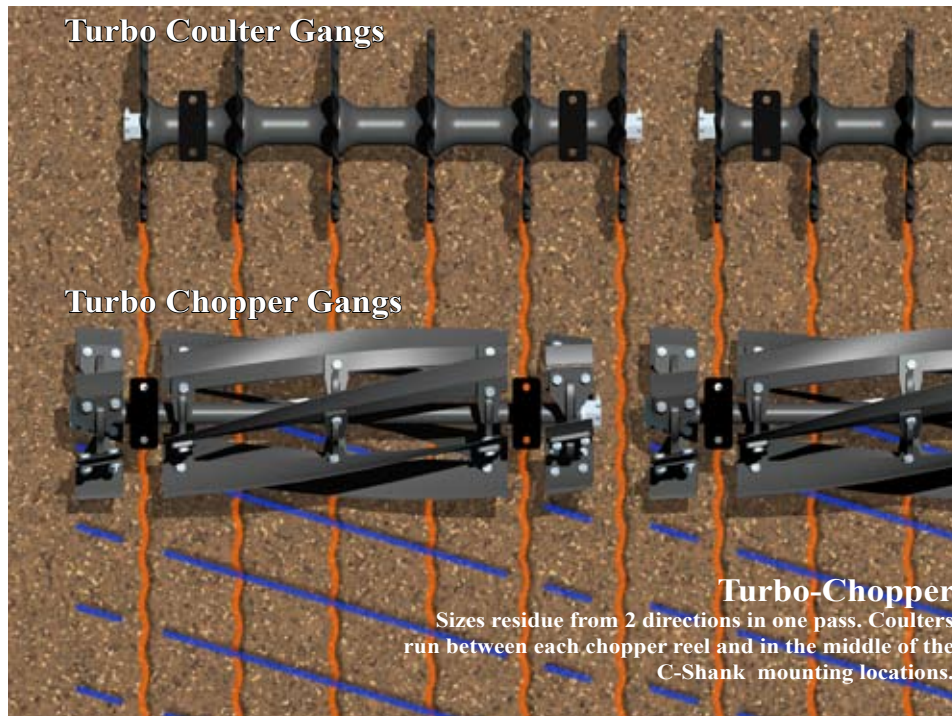

**Turbo-Chopper**  
Sizes residue from 2 directions in one pass. Coulters run between each chopper reel and in the middle of the C-Shank mounting locations.

### RUGGED 3” C-SHANK



3” C-Shank’s provide excellent gang support and protection in rocks.

### HYD. WEIGHT TRANSFER

(Folding model only)



Insures even level tillage depth across entire unit by actively transferring weight from the center section to the wings.



### CHOPPER BLADES

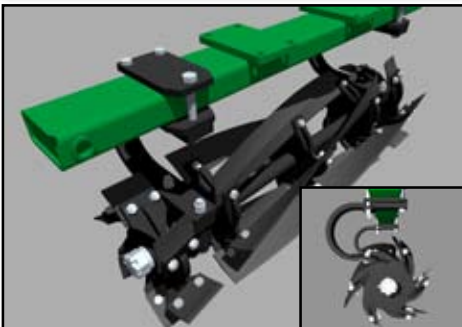

The angled chopper blades run perpendicular to the Turbo blades ensuring complete and through chopping of the residue and a profile that is level and uniform to the depth of the front coulters.

### CHOPPER GANGS



Both the Turbo gang and the chopper gang are suspended by 1" x 3" C-shanks and both gangs use the heavy duty 211 rubber cushioned cast bearing to provide reliable service.

### ROLLING SPIKE HARROW



It is highly recommended the Turbo-Chopper be equipped with the rolling spike harrow and reel. This attachment puts the "finishing touch" on the perfect seedbed.

### SPECIFICATIONS (all folding models offer hydraulic weight transfer)

Model Name	1500TC	1800TC	2400TC	3000TC	4000TC
Working Width	15' 6" Rigid	18' Folding	23' 10" Folding	30' 6" Folding	40' 6" Folding
Transport Width	15' 7"	12' 3"	15' 7"	15' 7"	17' 6"
Est. Weight	7,420 lbs.	9,240 lbs.	11,240 lbs.	12,900 lbs.	16,500 lbs.
Tires	(4)11L x 15 12P	(2)15L x 16.5 20P	(6)11L x 15 LRF	(8)12.5L x 15 LRF	(4)12.5L x 15 12PLY
Drawbar Horsepower Requirement	120-160	150-190	180-250	240-315	310-400
Center Section Size	Center 15'	Center 8'	Center 10'	Center 10'	Center 12'
1st Wing Section Size	N/A	Wings 5'	Wings 6' 9"	Wings 10'	Wings 10'
2nd Wing Section Size	N/A	N/A	N/A	N/A	Wings 4'

### STANDARD EQUIPMENT

- 20" Turbo Blades on 10" Spacing
- 1" x 3" HD C-shank Mounts
- HD Frame
- Single Point Depth Stop
- Constant Level Hitch
- Heavy Duty Light Package
- Heavy Duty Jack
- 211 Rubber Cushioned Cast Bearings
- 18" 6 Blade Chopper Reel

### OPTIONS

- 1/4" Thick Blades
- Weight Package
- Rolling Spike w/Reel

Note: All specifications subject to change without notice.