







**BERTI**<sup>®</sup>  
MACCHINE AGRICOLE

TA/LI  
TA/L



-  TRINCIARGINI PER TRATTORI DA 35 A 55 HP
-  IN-LINE AND OFFSET MULCHERS FOR TRACTORS FROM 35 TO 55 HP
-  BÖSCHUNGSMULCHER FÜR TRAKTOREN VON 35 BIS 55 PS
-  BROYEURS MULTIFONCTIONS POUR TRACTEURS DE 35 A 55 CV
-  TRITURADORAS DE LADERAS PARA TRACTORES DE 35 A 55 CV

# TA/LI

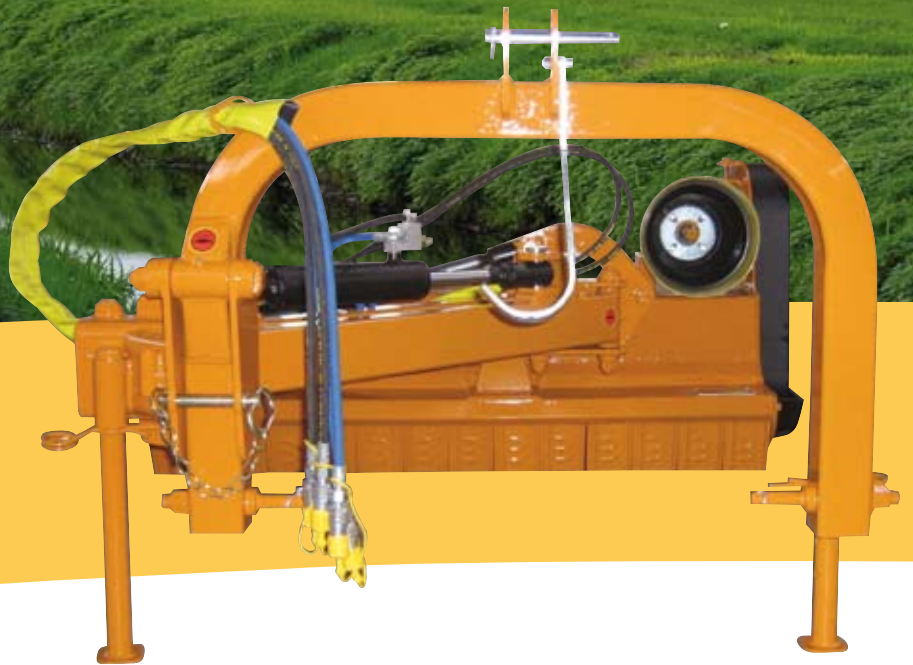

Trinciatrice compatta multiuso, da applicare a trattori con potenza compresa tra 35 e 55 HP. Adatta a lavorare sia posteriormente che lateralmente al trattore. E' consigliata per erba, residui vegetali, cespugli e sarmenti di Ø 2 cm. Ideale per la pulizia di parchi, aree verdi, giardini, bordi di strade, su fossati, argini e terreni inclinati in genere.



Compact offset / in-line mulcher for grass, residue of vegetables, bushes and pruning (up to Ø 2 cm), suited for tractors from 35 to 55 HP. Ideal for parks, green areas, gardens, slopes, ditches, banks of watercourses.



Heck und Seitenmulcher für Gras, Vegetation, Reisig und Ästen bis 2 cm Ø für Traktoren von 35 bis 55 PS. Es eignet sich für Parks, Garten, Wiesen, Böschungen und Wassergraben.



Desbrozadora compacta indicada para la trituración de hierba, residuos vegetales, arbustos y restos de poda (hasta 2 cm Ø), para tractores de 35 a 55 C.V. Ideal para parques, áreas verdes, jardines, cunetas y terrenos en pendiente en general.



Broyeur d'accotement compact multifonctions pour broyer l'herbe, les déchets végétaux, les buissons et les sarments allant jusqu'à Ø 2 cm, indiqué pour tracteurs de 35 à 55 CV. Il est idéal pour les parcs, les espaces verts, les jardins, le rebord des routes, les fossés, les digues et les terrains inclinés.



- Sistema flottante con limitatore
- Floating device, with limiter
- Schwimmstellung-System mit Hubbegrenzer
- Système flottante avec limiteur
- Sistema de enganche flotante con limitador



- Protezione carter (TA/LI)
- Side-protection (TA/LI)
- Seitenschutz (TA/LI)
- Protection du carter (TA/LI)
- Protección del cárter de la transmisión (TA/LI)

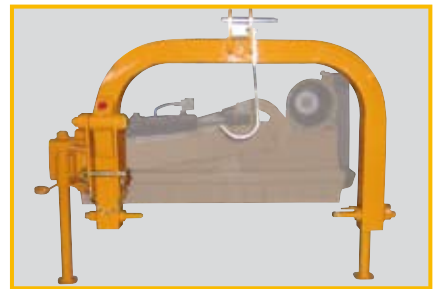

- Timone 3° punto con snodo oscillante
- 3-point linkage with floating link
- Dreipunktbock mit Schwimmstellung-System
- Attelage à 3 points avec système flottante
- Enganche a los tres puntos del tractor con enganche flotante



- Sistema antishock BERTI (optional)
- Exclusive BERTI Anti-Shock Device (optional)
- Anti-Schock System BERTI (optional)
- Système antichoc exclusif BERTI (optional)
- Dispositivo antichoque exclusivo de Berti (opcional)

# TA/L



Trinciatrice compatta multiuso, da applicare a trattori con potenza compresa tra 35 e 55 HP. Adatta a lavorare sia posteriormente che lateralmente al trattore. E' consigliata per erba, residui vegetali, cespugli e sarmenti di Ø 2 cm. Ideale per la pulizia di parchi, aree verdi, giardini, bordi di strade, su fossati, argini e terreni inclinati in genere.



Compact offset / in-line mulcher for grass, residue of vegetables, bushes and pruning (up to Ø 2 cm), suited for tractors from 35 to 55 HP. Ideal for parks, green areas, gardens, slopes, ditches, banks of watercourses.



Heck und Seitenmulcher für Gras, Vegetation, Reisig und Ästen bis 2 cm Ø für Traktoren von 35 bis 55 PS. Es eignet sich für Parks, Garten, Wiesen, Böschungen und Wassergraben.



Desbrozadora compacta indicada para la trituración de hierba, residuos vegetales, arbustos y restos de poda (hasta 2 cm Ø), para tractores de 35 a 55 C.V. Ideal para parques, áreas verdes, jardines, cunetas y terrenos en pendiente en general.



Broyeur d'accotement compact multifonctions pour broyer l'herbe, les déchets végétaux, les buissons et les sarments allant jusqu'à Ø 2 cm, indiqué pour tracteurs de 35 à 55 CV. Il est idéal pour les parcs, les espaces verts, les jardins, le rebord des routes, les fossés, les digues et les terrains inclinés.



- Protezione scatola ingranaggi (TA/L)
- Gearbox protection (TA/L)
- Getriebeschutz (TA/L)
- Protection du boîtier (TA/L)
- Protección de la caja de transmisión (TA/L)

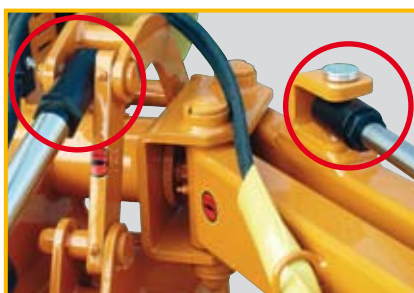

- Martinetti regolabili
- Adjustable cylinders (TA/L)
- Einstellbare hydr. Zylinder
- Vérins réglables
- Cilindros hidráulicos con extensión ajustable



- Giunto cardanico rinforzato
- Hardened PTO drive shaft
- Verstärkte Gelenkwelle
- Cardan à profil renforcé
- Eje de TDF reforzado

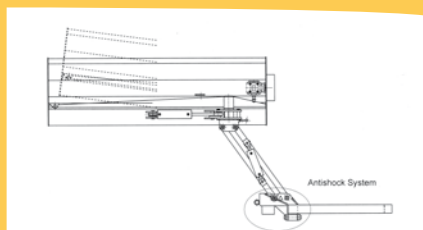

Mod.



A

B

C

D

E



cm

Min

Max

n°

n°

n°

PTO

cm

cm

cm

cm

cm

Kg

TA/LI

TA/LI 135

135

30

50

12

36

3

540

135

154

60

210

120

380

TA/LI 145

145

35

55

14

42

3

540

145

154

60

220

130

400

TA/LI 160

160

40

55

14

42

3

540

160

154

60

235

145

440

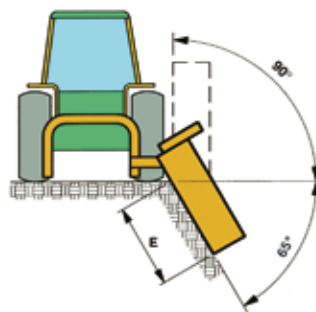
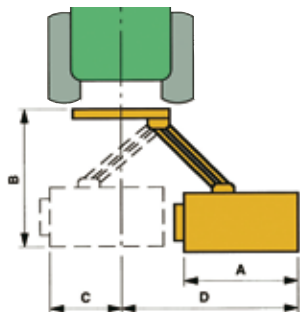

Mod.



A

B

C

D

E



cm

Min

Max

n°

n°

n°

PTO

cm

cm

cm

cm

cm

Kg

TA/L

TA/L 115

115

30

50

10

30

3

540

115

154

21

220

115

375

TA/L 135

135

35

55

12

36

3

540

135

154

21

240

135

395

TA/L 145

145

40

55

14

42

3

540

145

154

21

250

145

420

## OPTIONALS



- Slitte d'appoggio antiusura
- Skids of anti-wearing steel
- Satz Kufen mit Anti-Verschleißmaterial
- Jeu patins anti-usure
- Patines de acero reforzado anti-desgaste

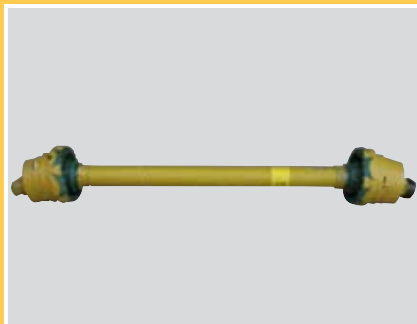

- Cardano doppio omocinetico
- Double Wide-Angle drive shaft
- Doppel-Weitwinkel Gelenkwelle
- Cardan double homocinétique
- Cardan doble homocinetico



- Distributore a doppio effetto con leve e cavi flessibili (o con tubi e innesti rapidi)
- Double effect distributor with levers and with wire-cables (or hoses and quick couplings)
- Doppelwirkendes Steuerventil mit Hebeln und Bowdenzügen (oder hydr. Schnellkupplungen)
- Distributeur hydraulique double effet à leviers avec téléflexibles en cabine (ou avec tuyaux et prises rapides)
- Distribuidor de doble efecto con palancas y cables flexibles (o latiguillos y enchufes rápidos)



- Mazza
- Hammer
- Schlegel
- Marteau
- Martillo

Standard



- Coltelli
- Blades
- Messer
- Couteaux
- Cuchillas

Optional

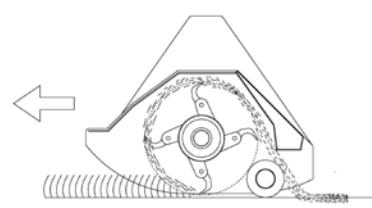

Le illustrazioni e i dati del presente catalogo sono indicative e non vincolanti per il costruttore • All pictures and data above are indicative only and not binding for the manufacturer  
 • Alle in diesem Katalog enthaltenen Angaben und Zeichnungen sind annähernd und unverbindlich • Toutes les données insérées dans ce catalogue ont été indiquées seulement à titre de renseignement • Las fotografías y los datos mostrados son meramente indicativos y podrían ser variados sin previo aviso por el fabricante



BERTI MACCHINE AGRICOLE S.p.A.  
 Via Musi 1/A | 37042 CALDIERO (VR) | ITALY  
 Tel. +39 045 6139711 - Fax +39 045 6150251  
 info@bertima.it

[www.bertima.it](http://www.bertima.it)

0389\_06