

Broadcast Spreaders

FSP500, FSP700 & FSP1000 Series			
	FSP500	FSP700	FSP1000
Capacity (Maximum Cu.ft. & pounds)	5.83 cu. ft. (350 lbs.)	9.18 cu. ft. (563 lbs.)	12.18 cu. ft. (673 lbs.)
Overall Dimensions	37" x 40"	44" x 46"	46.8" x 46"
Loading Height	36"	41"	44.5"
Weight	119	128	139
3-Point Attachment	Category 1	Category 1	Category 1
Net Spreadable Width			
Granular	39' - 46'	39' - 46'	39' - 46'
Crystalline	20' - 23'	20' - 23'	20' - 23'
PTO Attachment Type	1 3/8"	1 3/8"	1 3/8"
Transmission Ratio	1:1	1:1	1:1
Min. Tractor HP	15 HP	18 HP	20 HP
Range of Spreading Possibility (lbs/acre)	44 - 890	44 - 890	44 - 890

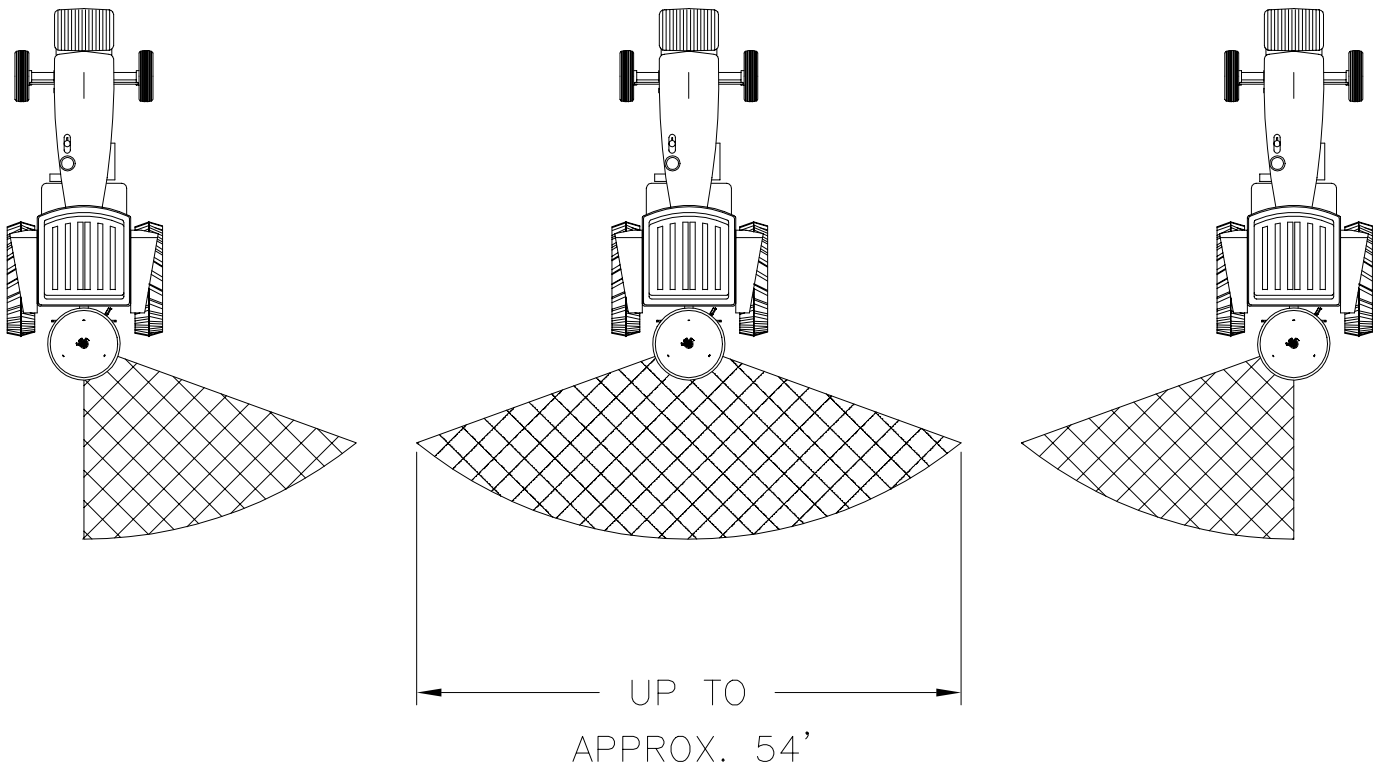

13613

Designs, specifications, features and information are subject to change without notice.

Features and Benefits

Spreaders

FSP500, FSP700 & FSP1000 Series

Features	Benefits
Hopper capacity	FSP500-350 lbs.; FSP700-563 lbs.; FSP1000-673 lbs. to meet specific customer needs.
Spreading capacity	Highly productive at 44 to 890 lbs. per acre.
Spin-type broadcast	For even spreading and productive coverage up to 54 ft.
One piece molded polyethylene hopper	Plastic construction to eliminate corrosion. Seamless for accurate and consistent emptying.
Heavy-duty tubular frame	Supports the weight when full.
Tow hook	Handles up to 1200 pounds.
540 RPM shielded PTO	For added safety.
Shielded Front	Prevents spreading of material in front of the spreader.
Stainless steel distributor vanes	Protects from corrosive material to enhance longevity.
Adjustable distributor vanes	Four adjustable positions to obtain maximum spreading precision and uniformity.
Plastic agitator wheel with steel arm	Standard equipment and is useful when spreading powder type materials that tend to bridge.
Stainless steel orifice doors	Protects from corrosive material enabling doors to operate smoothly.
Plated adjustment levers	Protects from corrosive material to enhance longevity.
Cat. 1 3-point hitch	For attachment to a wide range of tractors.

Designs, specifications, features and information are subject to change without notice.



[Home](#)
[Products](#)
[Manuals](#)
[Advertising](#)
[Support Center](#)
[Dealer Locator](#)
[Dealer Access](#)
[Finance](#)
[Search](#)
[Contact Us](#)

[Specifications](#)

[Features & Benefits](#)

[Operator's Manual](#)

[Parts Manuals](#)

[Literature](#)

[Media Library](#)

[Warranty](#)

[Locate A Dealer](#)

Photos may contain optional equipment.



[Return to *Spreader Selection*](#)

The Land Pride FSP500, FSP700, and FSP1000 are rotary/spin type broadcast spreaders designed for Category 1, three-point hitch mounting. They are capable of spreading seed, sand, salt, top dressings, and prilled/granular fertilizer, lime, and iron at delivery rates ranging from 43-890 lbs. per acre.

An internally mounted agitator helps keep material in the hopper from bridging. This ensures a continuous hopper flow and uniform delivery rate from the adjustable pattern rotary spreader. The spread rate capability and range of hopper capacities make the Land Pride Fertilizer Spreaders well suited for applications on farms, golf courses, park systems, athletic fields, and large campuses. They also work well for smaller municipal or commercial applications of salt and sand for snow and ice control.