

GRAPPIN PATU 18

Pour Chargeur jusqu'au modèle : **203T**



Grappin de **0,18m²**
Ouverture de 124cm (49"), pesant 67 kg (148 lbs) et très rapide à manoeuvrer.
Avec Rotateur :
(# **FR07**)

Rotator avec un angle de rotation continue



ROTATEUR FR07



ACCESSOIRES PATU

Grappins PATU

<i>Spécifications techniques</i>		<i>PATU 18</i> #11307001	<i>PATU 24</i> #11314001
<i>Superficie</i>	<i>m²</i>	0.18 (1.94 sqft)	0.24 (2.58 sqft)
<i>Pression d'opération</i>	<i>bar</i>	175 (2538 PSI)	175 (2538 PSI)
<i>Force de préhension</i>	<i>kN</i>	6.4 (1440 lbf)	8.5 (1910 lbf)
<i>Temps d'ouverture</i>	<i>s</i>	0.6	1.0
<i>@ 50 l/min (13 gpm imp.)</i>			
<i>Temps de fermeture</i>	<i>s</i>	0.9	1.3
<i>poids</i>	<i>kg</i>	67	115
		148 lbs	253 lbs

PATU 18

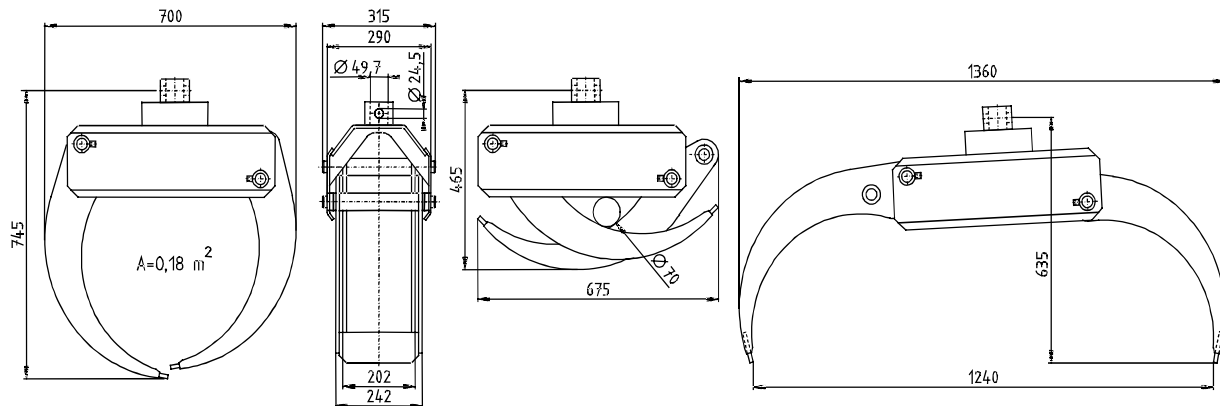

PATU 24

