



Welder • Generator • Compressor unit

Product & Accessories Catalog

January 2005



**Dynamic Power Source, LLC
1-877-693-7269**

**975 Progress Blvd. New Albany, IN 47150
www.187POWERBOX.com**

T A B L E O F C O N T E N T S

| | |
|---|-----------|
| Introduction | 3 |
| Key Components | 4 |
| Unit Drawings: | |
| Multi-Purpose | 5 |
| Drop-In Pickup (Gasoline) | 6 |
| Drop-In Pickup (Diesel) | 7 |
| Drop-In Service Body (Gasoline) | 8 |
| Drop-In Service Body (Diesel) | 9 |
| Integrated Service Body (Gasoline) | 10 |
| Integrated Service Body (Diesel) | 11 |
| Integrated Control Panel | 12 |
| PowerBox™ 280 | 13 |
| PowerBox™ 325 | 15 |
| PowerBox™ 415 | 17 |
| PowerBox™ 450 | 19 |
| PowerBox™ 175MP | 21 |
| PowerBox™ 240MP | 23 |
| PowerBox™ Battery Booster | 25 |
| PowerBox™ Hydraulic Circuit | 26 |

INTRODUCTION

Thank you for taking the time to inquire about the PowerBox™ universal power system. The PowerBox™ is a self-contained welder/generator/compressor unit designed to fit a variety of vehicle applications and user requirements. With six (6) models to choose from, gasoline and diesel engine configurations, multiple air and welding designs, and a variety of optional accessories, we are certain to have a PowerBox™ to meet your requirements and budget.

To assist you in selecting and purchasing the right PowerBox™, we have provided the following definitions:

Drop-In and Multi-Purpose Models- These units are designed to allow customers to perform an easy “drop-in” of the unit into existing pickup trucks, multi-purpose utility vehicles, and service bodies and require only four (4) bolts to install or remove the unit. These units are all inclusive packages and house the controls and access panel all in one unit. The following offers views of typical drop-in installations. Key selection points for choosing a drop-in or multi-purpose model include those customers that utilize vehicle configurations with:

- No flip-top lids / bed canopy
- No raised right or left front compartment sides
- Vehicle bed / body height of less than 48”; allowing for access to control panel

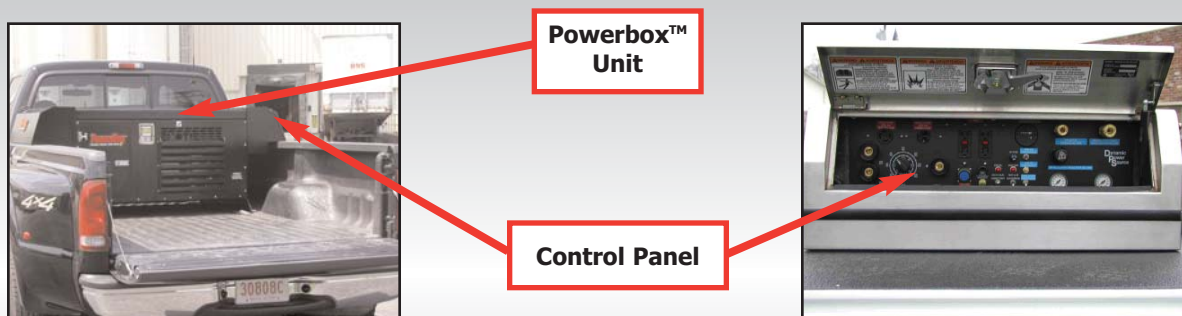

Integrated Service Body Models -These units allow customers to integrate the control panel of the PowerBox™ unit within the service body compartments or at the rear of the vehicle. The following offers views of typical integrated installations. Key selection points for choosing an integrated model include those customers that utilize vehicle configurations with:

- Vehicle bed / body height that utilizes a raised right or left compartment side making access to control panel prohibitive
- Vehicle bed / body equipped with a flip-top / bed canopy
- Requirement of additional security means

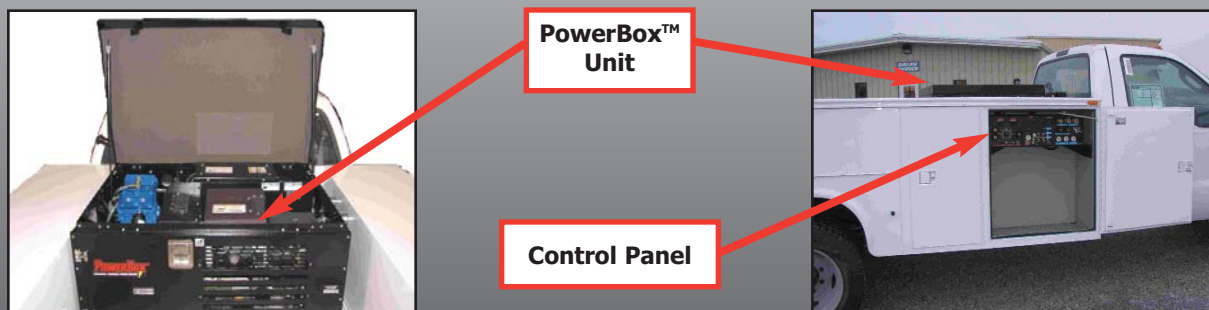

KEY COMPONENTS

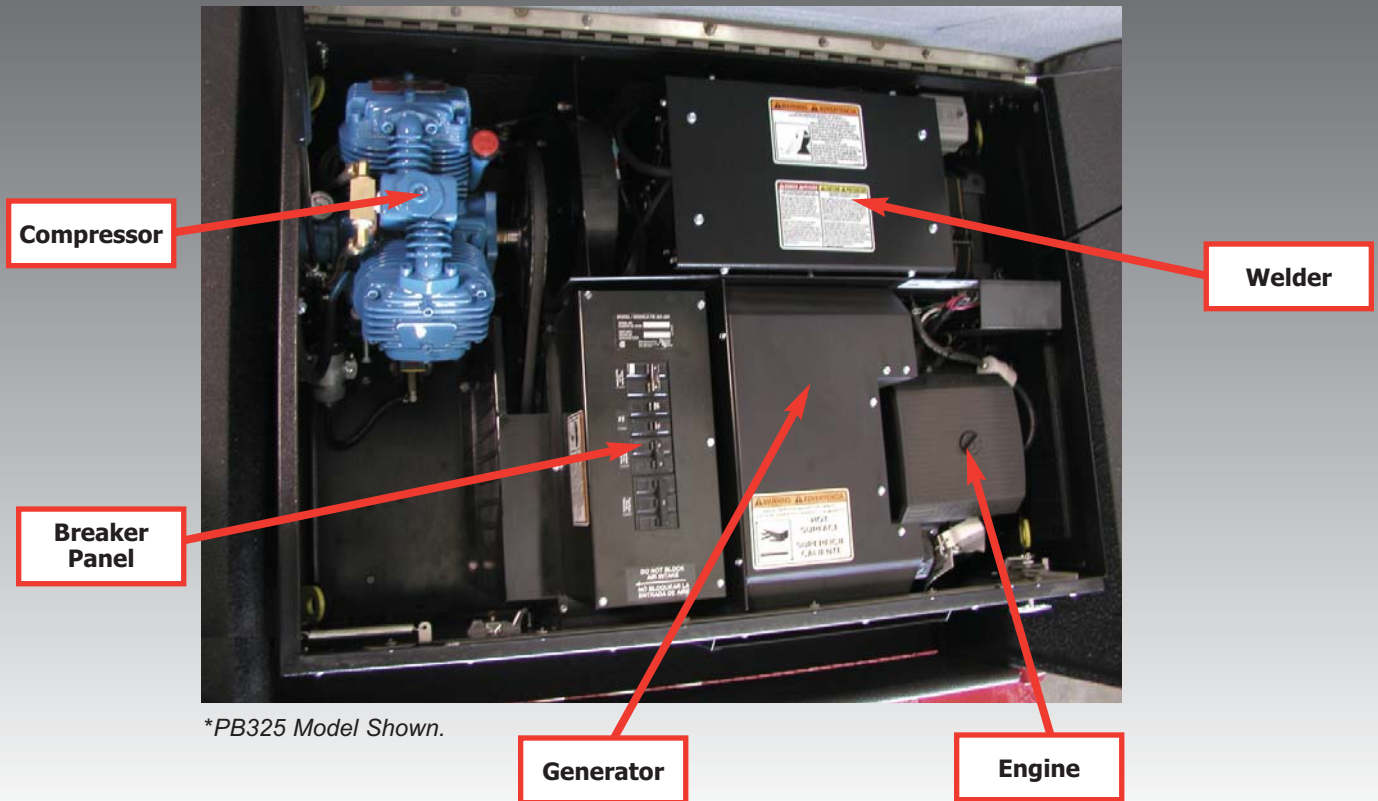

*PB325 Model Shown.

POWERBOX™ SELECTION GUIDE

| Model | Available Configurations | Power | *Air/CFM | Integrated Welding | Welding Amps | Hydraulics | Battery Booster |
|----------------|------------------------------------|---------|----------|--------------------|--------------|------------|-----------------|
| PB175MP (Gas) | Pickup, Svc. Body, Utility Vehicle | 7.5 KW | 13 | N/A | N/A | N/A | Optional |
| PB240MP (Gas) | Pickup, Svc. Body, Utility Vehicle | 5.5 KW | 13 | YES | 175 Amps | N/A | Optional |
| PB280 (Gas) | Pickup, Svc. Body, Int. Svc. Body | 6 KW | 13 | YES | 225 Amps | N/A | Optional |
| PB325 (Gas) | Pickup, Svc. Body, Int. Svc. Body | 8.5 KW | 13 / 30 | YES | 250 Amps | N/A | Optional |
| PB415 (Gas) | Pickup, Svc. Body, Int. Svc. Body | 12.8 KW | 30 / 65 | YES | 300 Amps | Optional | Optional |
| PB450 (Diesel) | Pickup, Svc. Body, Int. Svc. Body | 12.8 KW | 30 / 65 | YES | 350 Amps | N/A | Optional |

* Air options available

Please feel free to contact us with any questions at 877-693-7269 and thank you for considering our products.

MULTI-PURPOSE MODEL - GASOLINE

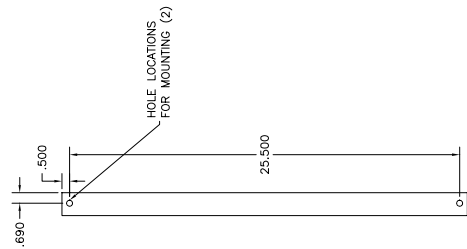
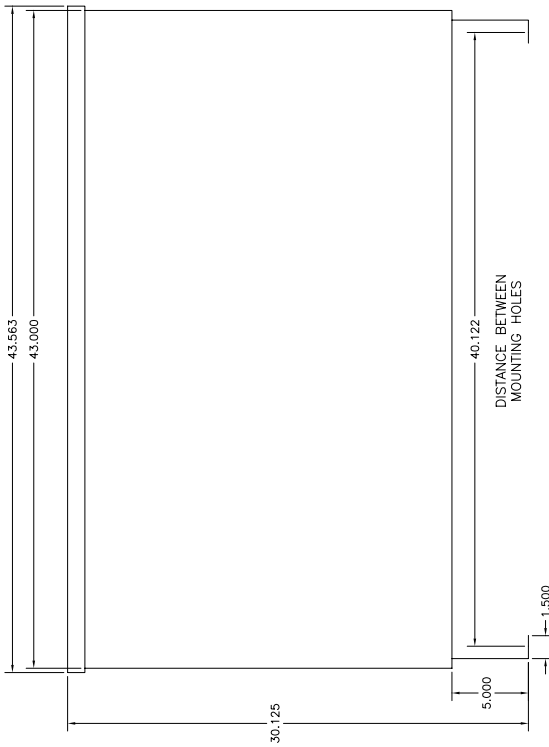
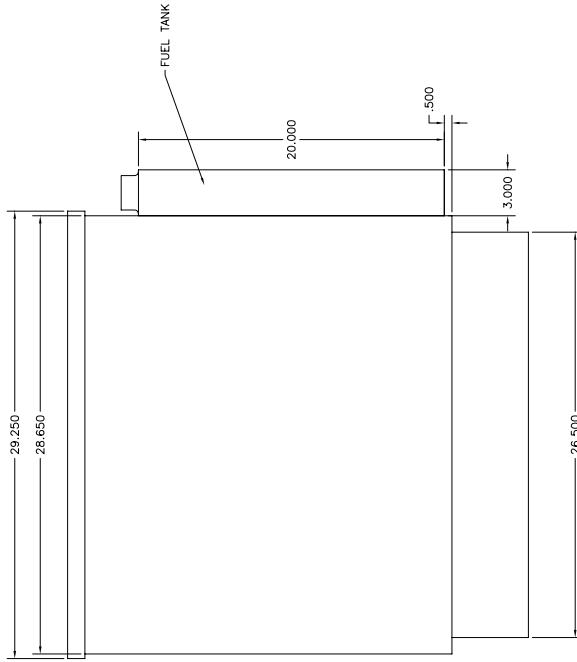

MULTI-PURPOSE MODEL

FITS MOST PICK-UPS
AND UTILITY VEHICLES

DROP-IN PICKUP - GASOLINE

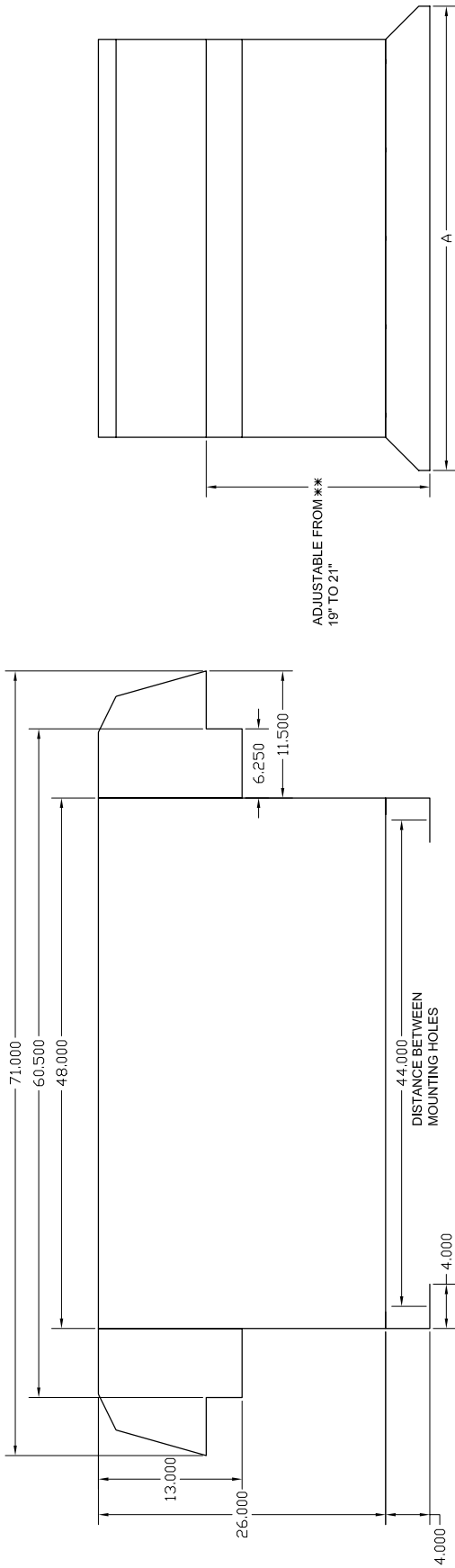

ADJUSTABLE FROM **
18" TO 21"

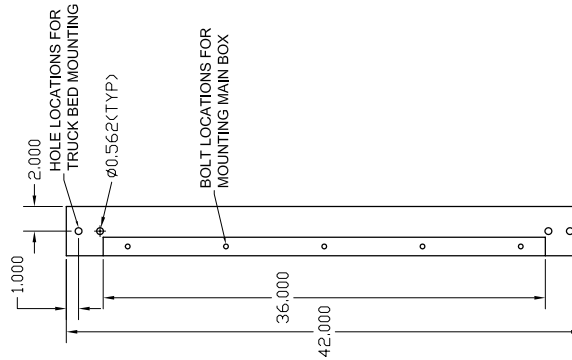

DROP-IN PICKUP BODY STYLE

| OPTIONS | DIM. "A" |
|--|-------------|
| STANDARD (AS SHOWN) | 42" |
| STANDARD WITH 70 CFM AIR | 42" |
| STANDARD WITH HYDRAULICS AND/OR BATTERY BOOSTER | 51" |
| STANDARD WITH 70 CFM AIR AND HYDRAULICS AND/OR BATTERY BOOSTER | 53.25" |

FITS STANDARD FULL-SIZE TRUCKS:
DODGE; FORD; CHEVROLET

DROP-IN PICKUP - DIESEL

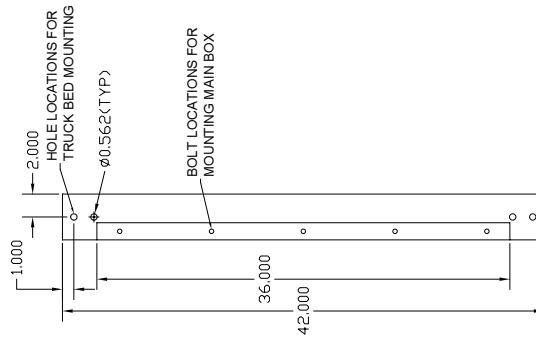
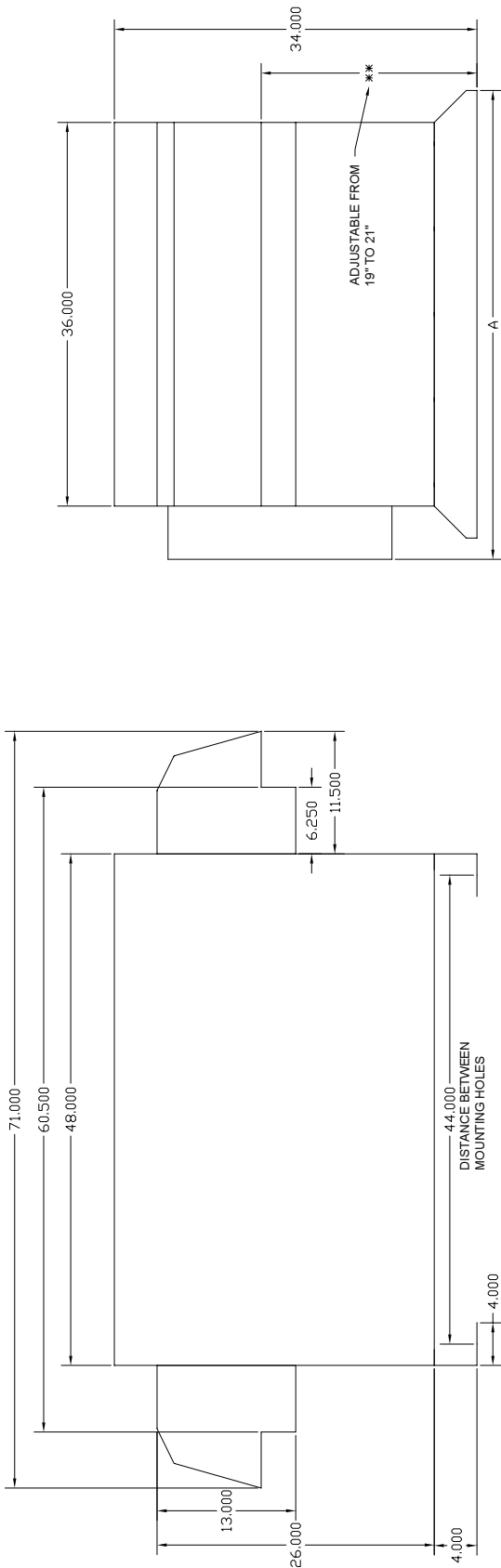

DROP-IN PICKUP
BODY STYLE (DIESEL)

FITS STANDARD FULL-SIZE TRUCKS:
DODGE; FORD; CHEVROLET

| OPTIONS | DIM. "A" |
|--|----------|
| STANDARD (AS SHOWN) | 44.5" |
| STANDARD WITH 70 CFM AIR | 44.5" |
| STANDARD WITH BATTERY BOOSTER | 56.5" |
| STANDARD WITH 70 CFM AIR AND BATTERY BOOSTER | 58.75" |

DROP-IN SERVICE BODY - GASOLINE

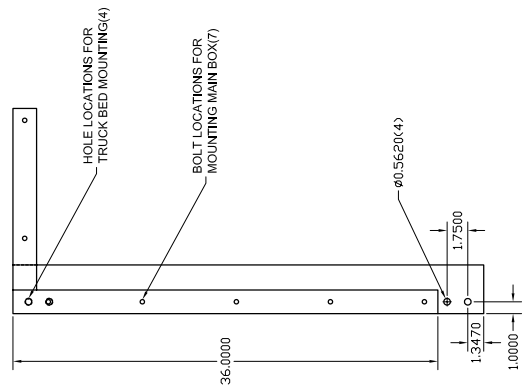
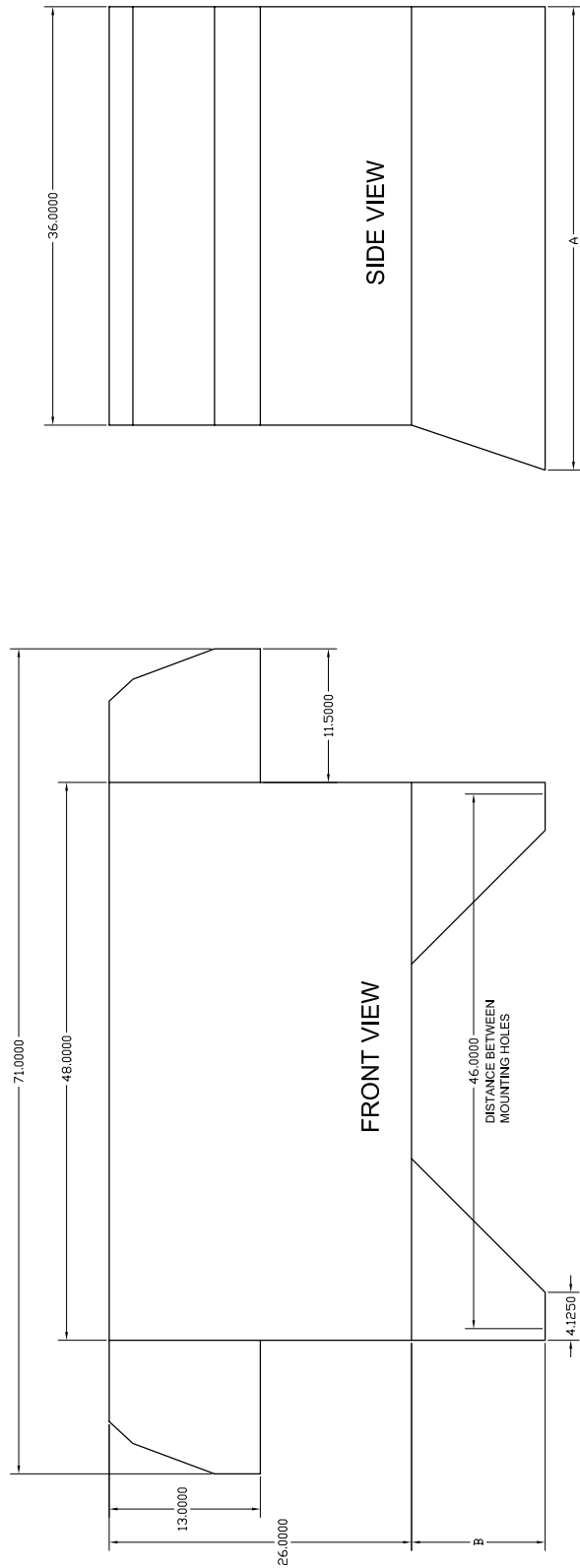

| OPTIONS | DIM. "A" |
|--|----------|
| STANDARD (AS SHOWN) | 39.875" |
| STANDARD WITH 70CFM AIR | 42.125" |
| STANDARD WITH HYDRAULICS AND/OR BATTERY BOOSTER | 51.875" |
| STANDARD WITH 70 CFM AIR AND HYDRAULICS AND/OR BATTERY BOOSTER | 54.125" |

| OPTIONS | DIM. "B" |
|---------|----------|
| STYLE 1 | 11.5" |
| STYLE 2 | 13.5" |

DROP-IN SERVICE BODY

DROP-IN SERVICE BODY - DIESEL

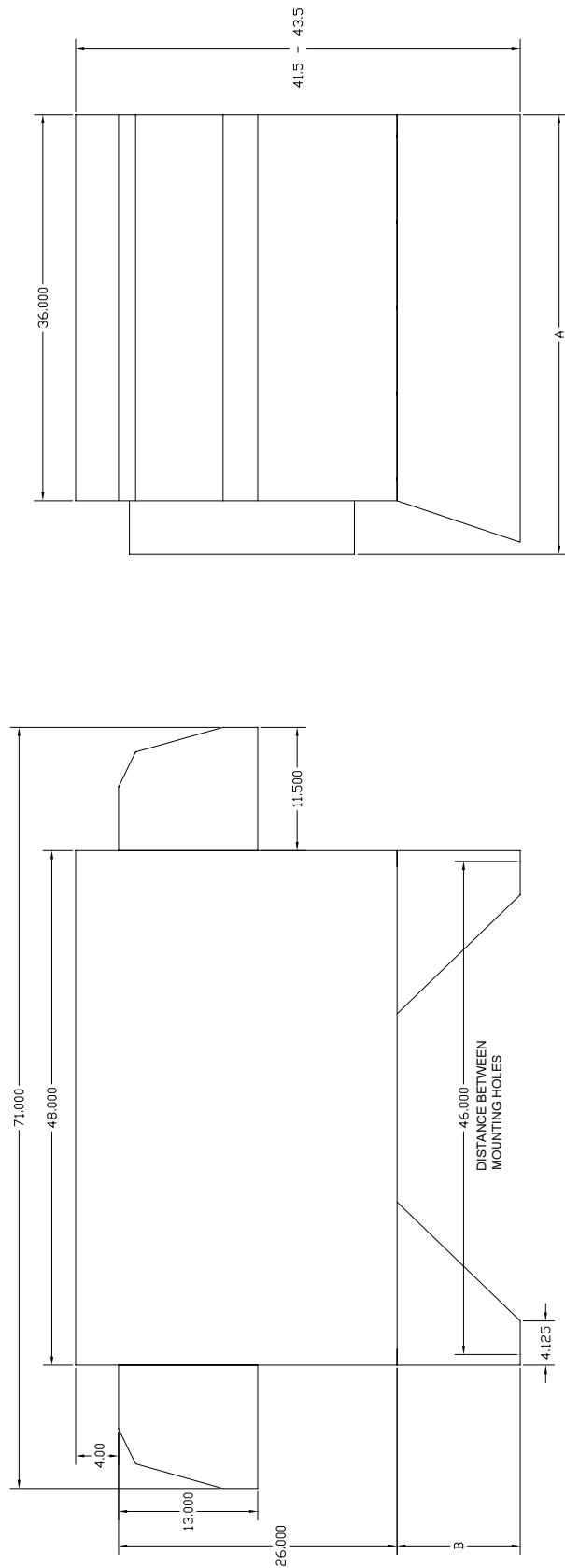

| DIESEL OPTIONS | DIM. "A" |
|--|----------|
| STANDARD (AS SHOWN) | 41.5" |
| STANDARD WITH 70 CFM AIR | 43.75" |
| STANDARD WITH BATTERY BOOSTER | 53.5" |
| STANDARD WITH 70 CFM AIR AND BATTERY BOOSTER | 55.75" |

| OPTIONS | DIM. "B" |
|---------|----------|
| STYLE 1 | 11.5" |
| STYLE 2 | 13.5" |

DROP-IN SERVICE BODY (DIESEL)

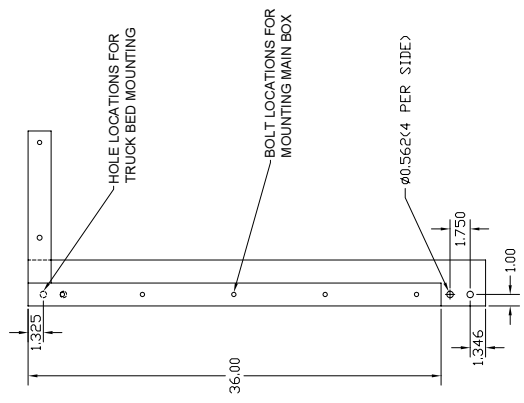

INTEGRATED SERVICE BODY - GASOLINE

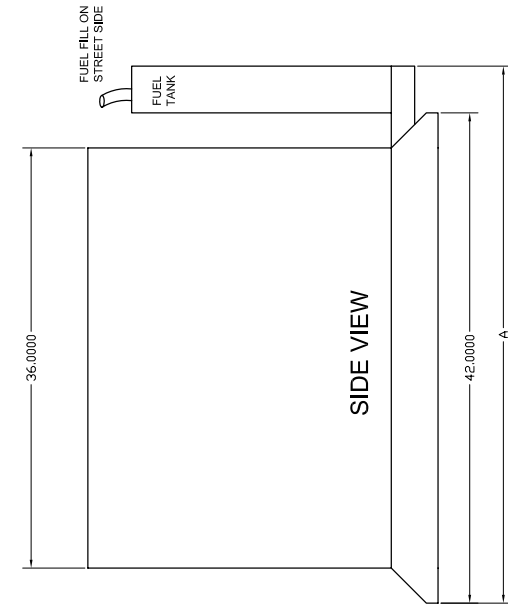

| OPTIONS | DIM. "A" |
|--|----------|
| STANDARD (AS SHOWN) | 46" |
| STANDARD WITH 70CFM AIR | 48.25" |
| STANDARD WITH HYDRAULICS AND/OR BATTERY BOOSTER | 54.5" |
| STANDARD WITH 70 CFM AIR AND HYDRAULICS AND/OR BATTERY BOOSTER | 57.75" |

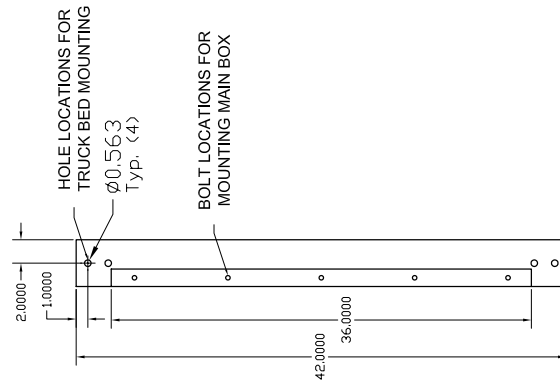
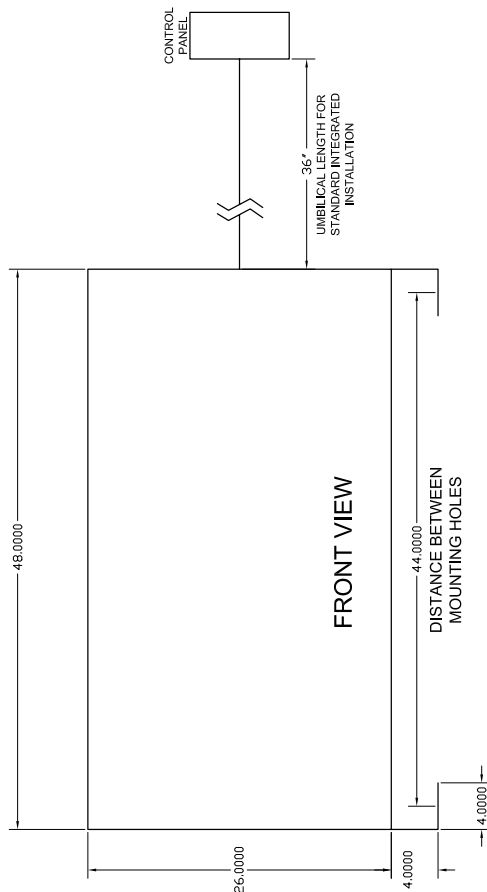

INTEGRATED SERVICE BODY

Integrated Service Body - Diesel

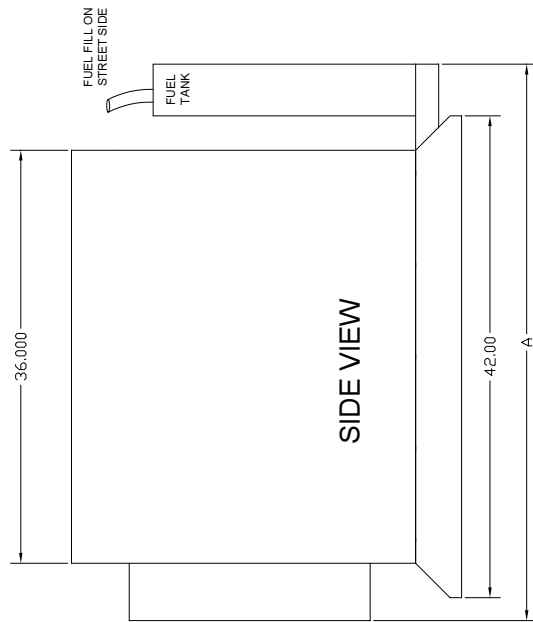

| DIESEL OPTIONS | DIM. "A" |
|--|----------|
| STANDARD (AS SHOWN) | 48.5" |
| STANDARD WITH 70 CFM AIR | 50.75" |
| STANDARD WITH BATTERY BOOSTER | 61" |
| STANDARD WITH 70 CFM AIR AND BATTERY BOOSTER | 63.25" |

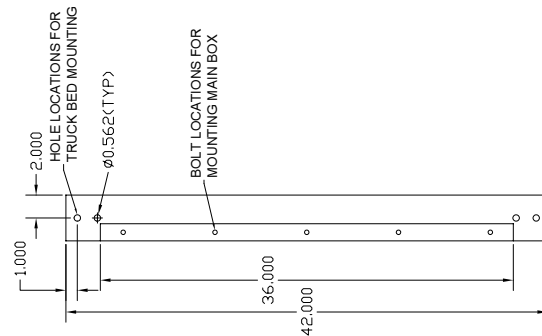
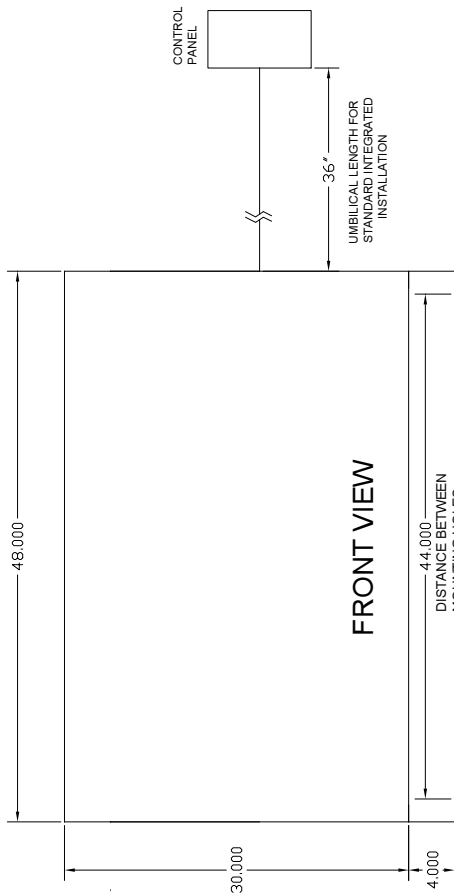

INTEGRATED SERVICE BODY (DIESEL)

INTEGRATED CONTROL PANEL

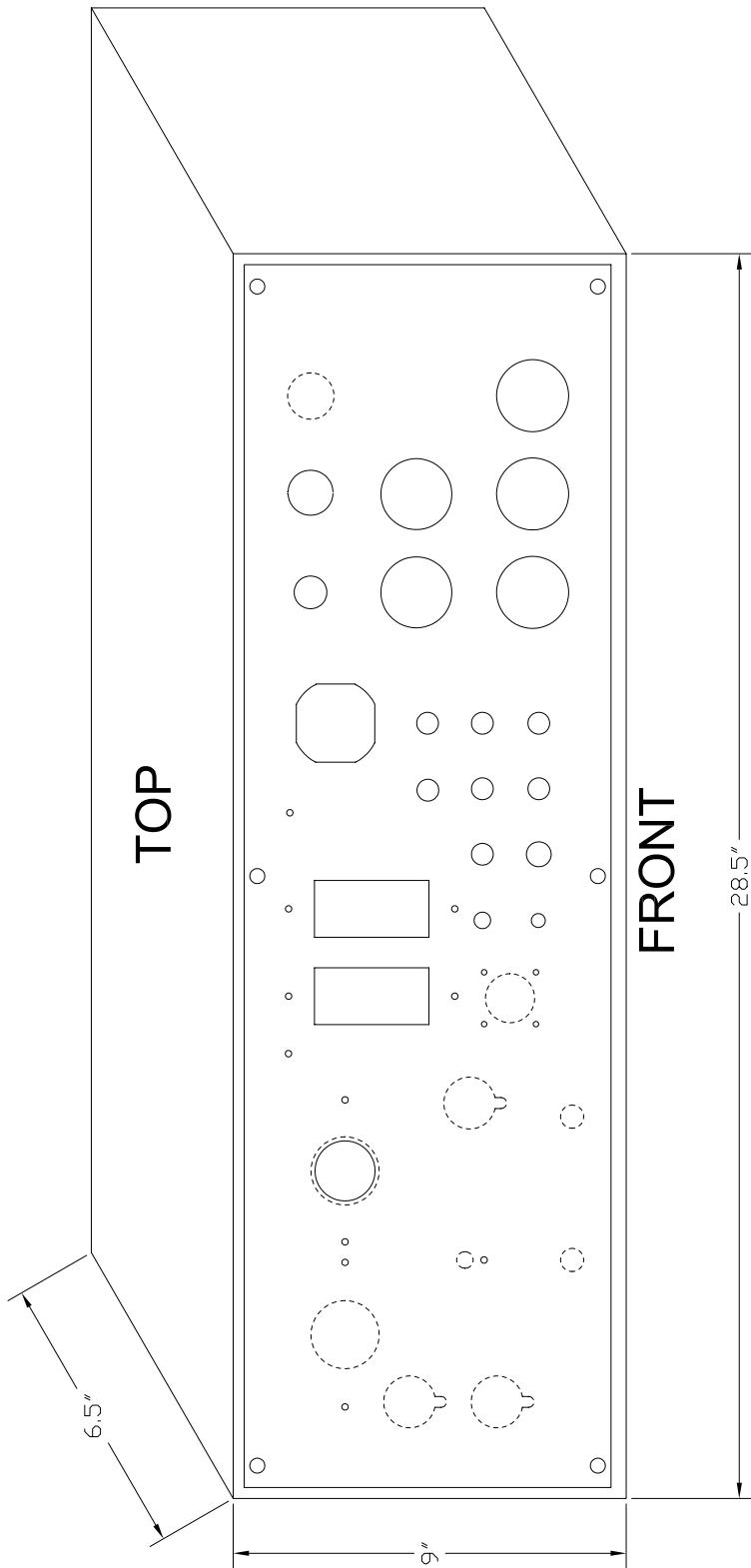

INTEGRATED CONTROL PANEL DIMENSIONS

PowerBox™ 280

Welder • Generator • Compressor unit

Typical Applications:

The **PowerBox™280** is ideal for the professional that requires the ability to:

- Run power tools (i.e., saws, drills, grinders, lights, sanders, etc.)
- Run air tools (i.e., impact wrenches up to 1/2", ratchets, grinders, nailers, etc.)
- Perform general welding repair and fabrication
- Jump start vehicles/equipment (w/optional booster)

Engine:

- 20 hp Kohler® Command Pro® Gasoline, air-cooled

Welding Capacity:

- Integrated 225 Amp (@ 100% duty cycle) DC welder

Output Range:

- DC-CC = 60 - 225 Amps

Maximum Available Power:

- (60 Hz) 7.5 KVA alternator
- Maximum Output 6,000 watts
- 115v AC - Single Phase 6,000 watts (40 Amp)
- 230v AC - Single Phase 6,000 watts (20 Amp)
- Auxiliary power (welding) 1,000 - 6,000 Watts

Electrical Outlets:

- 230v Single Phase (20 Amp)
- Two (2) 110v (20 Amp) GFCI duplex receptacles

Air Compressor:

- 2 pumps 13 CFM @ 100 PSI
- Maximum 150 PSI available
- 10 gallon air storage tank
- One (1) 1/4" regulated outlet
- One (1) 3/8" regulated outlet

Dimensions:

- Height: 29"
- Width: 36"
- Length: 48"

Weight:

- 850 lbs.



POWERBOX™
UNIVERSAL PORTABLE POWER SOURCE

Drop-In Pickup Trucks



Integrated Service Bodies



Drop-In Service Bodies



Products

| Part # | Drop-In Pickup Model |
|------------------------|--|
| PB280MSP-13-225 | Includes all standard features plus: Painted trim, lockable control panel, integrated 11 gallon fuel tank, lifting sling, 25' stick welding lead (stinger and ground clamp), integrated welder and 13CFM compressors max. 145 PSI. |

| Part # | Integrated Service Body Model* |
|------------------------|--|
| PB280MSI-13-225 | Includes all standard features plus: Painted trim, lockable control panel, integrated slim line 15 gallon fuel tank, lifting sling, 25' stick welding lead (stinger and ground clamp), integrated welder and 13CFM compressors max. 145 PSI. |

*In order to ensure proper fit, please specify make and model of service body at time of order. The PowerBox™ installed has 4" clearance from bottom of unit to truck bed. Custom base required if more clearance is needed.

| Part # | Drop-In Service Body Model** |
|------------------------|--|
| PB280MSD-13-225 | Includes all standard features plus: Painted trim, lockable control panel, integrated 11 gallon fuel tank, lifting sling, 25' stick welding lead (stinger and ground clamp), integrated welder and 13CFM compressors max. 145 PSI. |

**Includes custom base. In order to ensure proper fit, please specify make and model of service body at time of order. The PowerBox™ installed has 12" - 18" clearance from bottom of unit to truck bed.

Accessories

| Part # | PowerBox™ Brand Accessories |
|-------------------|--|
| 14-1000-00 | 25' Stick welding lead extension. |
| SA-1070-00 | Integrated 12/24 volt, 90 Amp continuous, 800 Amp battery jumper booster w/ 17' cables standard. see pg 25 |

| Part # | Other Accessories |
|-------------------|--------------------------------------|
| 14-0195-00 | Miller® Spectrum® 375 Plasma Cutter. |

PowerBox™ 325

Welder • Generator • Compressor unit

Typical Applications:

The **PowerBox™325** is ideal for the professional that requires the ability to:

- Run power tools (i.e., saws, drills, grinders, lights, sanders, etc.)
- Run air tools (i.e., impact wrenches, ratchets, grinders, nailers, etc.)
 - 13 CFM (up to 1/2 inch impact wrench)
 - 30 CFM (up to 1 inch impact wrench)
- Perform general welding repair and fabrication
- Jump start vehicles/equipment (w/optional booster)

Engine:

- 20 hp Kohler® Command Pro® Gasoline, air-cooled

Welding Capacity:

- Integrated 250 Amp (@ 100% duty cycle) DC welder

Output Range:

- DC-CC = 30 - 250 Amps
- DC-CV = 15 - 30 volts

Maximum Available Power:

- (60 Hz) 10 KVA alternator
- Maximum Output 8,500 watts
- 115v AC - Single Phase 8,500 watts (40 Amp)
- 230v AC - Single Phase 8,500 watts (20 Amp)
- 230v AC - Three Phase 8,500 watts (20 Amp)
- Auxiliary power (welding) 1,000 - 8,500 watts

Electrical Outlets:

- 230v Three Phase (20 Amp)
- 230v Single Phase (20 Amp)
- Two (2) 110v (20 Amp) GFCI duplex receptacles

Air Compressor:

- 13 or 30 CFM @ 100 PSI
- Maximum 150 PSI available
- 10 gallon air storage tank
- One (1) 1/4" regulated outlet
- One (1) 3/8" regulated outlet

Dimensions:

- Height: 29"
- Width: 36"
- Length: 48"

Weight:

- 950 lbs.

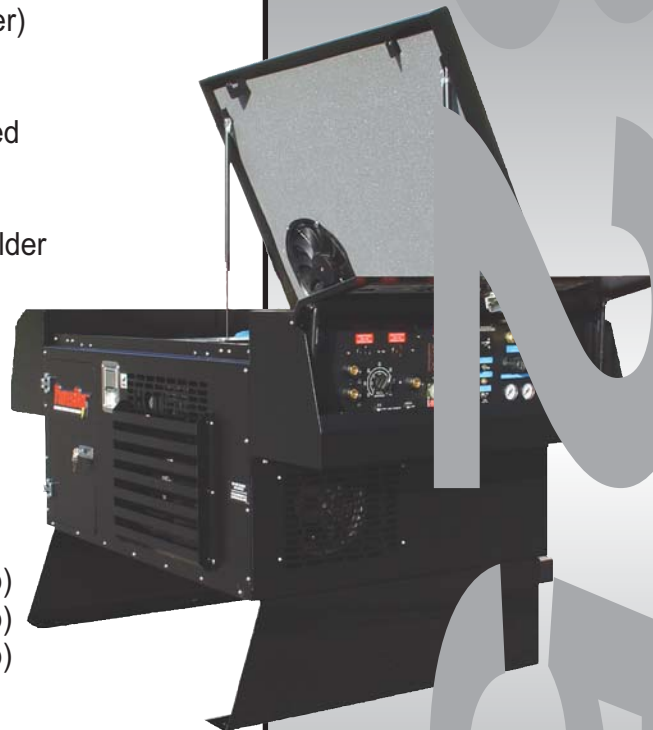

Drop-In Pickup Trucks



Integrated Service Bodies



Drop-In Service Bodies



Products

| Part # | Drop-In Pickup Model |
|------------------------|---|
| PB325MSP-13-250 | Includes all standard features plus: Painted trim, lockable control panel, integrated 11 gallon fuel tank, lifting sling, 25' stick welding lead (stinger and ground clamp), integrated welder and 13CFM compressors max. 145 PSI. |
| PB325MSP-37-250 | Includes all standard features plus: Painted trim, lockable control panel, integrated 11 gallon fuel tank, lifting sling, 25' stick welding lead (stinger and ground clamp), integrated welder and compressor upgrade: 30CFM max. 145 PSI. |

| Part # | Integrated Service Body Model* |
|------------------------|---|
| PB325MSI-13-250 | Includes all standard features plus: Painted trim, lockable control panel, integrated slim line 15 gallon fuel tank, lifting sling, 25' stick welding lead (stinger and ground clamp), integrated welder and 13CFM compressors max. 145 PSI. |
| PB325MSI-37-250 | Includes all standard features plus: Painted trim, lockable control panel, integrated slim line 15 gallon fuel tank, lifting sling, 25' stick welding lead (stinger and ground clamp), integrated welder and compressor upgrade: 30CFM max. 145 PSI. |

*In order to ensure proper fit, please specify make and model of service body at time of order. The PowerBox™ installed has 4" clearance from bottom of unit to truck bed. Custom base required if more clearance is needed.

| Part # | Drop-In Service Body Model** |
|------------------------|---|
| PB325MSD-13-350 | Includes all standard features plus: Painted trim, lockable control panel, integrated 11 gallon fuel tank, lifting sling, 25' stick welding lead (stinger and ground clamp), integrated welder and 13CFM compressors max. 145 PSI. |
| PB325MSD-37-250 | Includes all standard features plus: Painted trim, lockable control panel, integrated 11 gallon fuel tank, lifting sling, 25' stick welding lead (stinger and ground clamp), integrated welder and compressor upgrade: 30CFM max. 145 PSI. |

**Includes custom base. In order to ensure proper fit, please specify make and model of service body at time of order. The PowerBox™ installed has 12" - 18" clearance from bottom of unit to truck bed.

Accessories

| Part # | PowerBox™ Brand Accessories |
|-------------------|---|
| 14-1000-00 | 25' Stick welding lead extension. |
| SA-1070-00 | Integrated 12/24 volt, 90 Amp continuous, 800 Amp battery jumper booster w/ 17' cables standard. see pg 25 |

| Part # | Other Accessories |
|-------------------|--------------------------------------|
| 14-0195-00 | Miller® Spectrum® 375 Plasma Cutter. |

PowerBox™ 415

Welder • Generator • Compressor unit
Optional 6-8 GPM Hydraulic Circuit

Typical Applications:

The **PowerBox™415** is ideal for the professional that requires the ability to:

- Run power tools (i.e., saws, drills, grinders, lights, sanders, etc.)
- Run air tools (i.e., impact wrenches, ratchets, grinders, nailers, etc.)
 - 30 CFM (up to 1 inch impact wrench)
 - 65 CFM (air/arc gouging, use of multiple air tools simultaneously, etc.)
- Perform heavy duty welding repair and fabrication
- Run hydraulic drive hand tools and vehicle mounted cranes and lifts (with optional Hydraulic Circuit)
- Jump start vehicles/equipment (w/optional booster)

Engine:

- 27 hp Kohler® Command Pro® Gasoline, air-cooled

Welding Capacity:

- Integrated 300 Amp (@ 100% duty cycle) DC welder

Output Range:

- DC-CC = 30 - 300 Amps
- DC-CV = 15 - 30 volts

Maximum Available Power:

- (60 Hz) 15 KVA alternator
- Maximum Output 12,800 watts
- 115v AC - Single Phase 12,800 watts (30 Amp)
- 230v AC - Single Phase 12,800 watts (30 Amp)
- 230v AC - Three Phase 12,800 watts (30 Amp)
- Auxiliary power (welding) 1,000 - 12,800 watts

Electrical Outlets:

- 230v Three Phase (20 Amp)
- 230v Single Phase (20 Amp)
- Two (2) 110v (20 Amp) GFCI duplex receptacles

Air Compressor:

- 1 pump 30 or 65 CFM (Rotary Screw) @ 100 PSI
- Maximum 150 PSI available
- 10 gallon air storage tank (30 CFM Only)
- One (1) 1/4" regulated outlet
- One (1) 3/8" regulated outlet
- One (1) 3/8" non-regulated outlet

Dimensions:

- Height: 29"
- Width: 36"
- Length: 48"

Weight:

- 1150 lbs.



POWERBOX™
UNIVERSAL PORTABLE POWER SOURCE

Drop-In Pickup Trucks



Integrated Service Bodies



Drop-In Service Bodies



Products

| Part # | Drop-In Pickup Model |
|------------------------|---|
| PB415MSP-37-300 | Includes all standard features plus: Painted trim, lockable control panel, integrated 11 gallon fuel tank, lifting sling, 25' stick welding lead (stinger and ground clamp), integrated welder and 30 CFM compressor max. 145 PSI. |
| PB415MSP-70-300 | Includes all standard features plus: Painted trim, lockable control panel, integrated 11 gallon fuel tank, lifting sling, 25' stick welding lead (stinger and ground clamp) and compressor upgrade to 65 CFM rotary screw max. 145 PSI. Welder must be mounted remotely. |

| Part # | Integrated Service Body Model* |
|------------------------|---|
| PB415MSI-37-300 | Includes all standard features plus: Painted trim, lockable control panel, integrated slim line 15 gallon fuel tank, lifting sling, 25' stick welding lead (stinger and ground clamp), integrated welder and 30 CFM compressor max. 145 PSI. |
| PB415MSI-70-300 | Includes all standard features plus: Painted trim, lockable control panel, integrated slim line 15 gallon fuel tank, lifting sling, 25' stick welding lead (stinger and ground clamp) and compressor upgrade: 65 CFM rotary screw max. 145 PSI. Welder must be mounted remotely. |

*In order to ensure proper fit, please specify make and model of service body at time of order. The PowerBox™ installed has 4" clearance from bottom of unit to truck bed. Custom base required if more clearance is needed.

| Part # | Service Body Drop-In Model** |
|------------------------|---|
| PB415MSD-37-300 | Includes all standard features plus: Painted trim, lockable control panel, integrated 11 gallon fuel tank, lifting sling, 25' stick welding lead (stinger and ground clamp), integrated welder and 30 CFM compressor max. 145 PSI. |
| PB415MSD-70-300 | Includes all standard features plus: Painted trim, lockable control panel, integrated 11 gallon fuel tank, lifting sling, 25' stick welding lead (stinger and ground clamp) and compressor upgrade: 65 CFM rotary screw max. 145 PSI. Welder must be mounted remotely. |

**Includes custom base. In order to ensure proper fit, please specify make and model of service body at time of order. The PowerBox™ installed has 12" - 18" clearance from bottom of unit to truck bed.

Accessories

| Part # | PowerBox™ Brand Accessories |
|-------------------|--|
| 14-1000-00 | 25' Stick welding lead extension. |
| 20-1000-00 | Integrated Hydraulic Circuit - 6-8 GPM @ 3000 PSI. <i>see pg 26</i> |
| SA-1070-00 | Integrated 12/24 volt, 90 Amp continuous, 800 Amp battery jumper booster w/ 17' cables standard. <i>see pg 25</i> |

| Part # | Other Accessories |
|-------------------|--------------------------------------|
| 14-0195-00 | Miller® Spectrum® 375 Plasma Cutter. |

PowerBox™ 450 Diesel

Welder • Generator • Compressor unit

Typical Applications:

The **PowerBox™450 Diesel** is ideal for the professional that requires the ability to:

- Run power tools (i.e., saws, drills, grinders, lights, sanders, etc.)
- Run air tools (i.e., impact wrenches, ratchets, grinders, nailers, etc.)
 - 30 CFM (up to 1 inch impact wrench)
 - 65 CFM (air/arc gouging, use of multiple air tools simultaneously, etc.)
- Perform heavy duty welding repair and fabrication
- Perform operations with diesel fuel
- Jump start vehicles/equipment (w/optional booster)

Engine:

- 34 hp Kubota® (4-cylinder) diesel, water-cooled

Welding Capacity:

- Integrated 350 Amp (@ 100% duty cycle) DC welder

Output Range:

- DC-CC = 30 - 350 Amps
- DC-CV = 15 - 30 volts

Maximum Available Power:

- (60 Hz) 15 KVA alternator
- Maximum Output 12,800 watts
- 115v AC - Single Phase 12,800 watts (30 Amp)
- 230v AC - Single Phase 12,800 watts (30 Amp)
- 230v AC - Three Phase 12,800 watts (30 Amp)
- Auxiliary power (welding) 1,000 - 12,800 watts

Electrical Outlets:

- 230v Three Phase (20 Amp)
- 230v Single Phase (20 Amp)
- Two (2) 110v (20 Amp) GFCI duplex receptacles

Air Compressor:

- 1 pump 30 or 65 CFM (Rotary Screw) @ 100 PSI
- Maximum 150 PSI available
- 10 gallon air storage tank (30 CFM Only)
- One (1) 1/4" regulated outlet
- One (1) 3/8" regulated outlet
- One (1) 3/8" non-regulated outlet

Dimensions:

- Height: 29"
- Width: 36"
- Length: 48"

Weight:

- 1650 lbs.

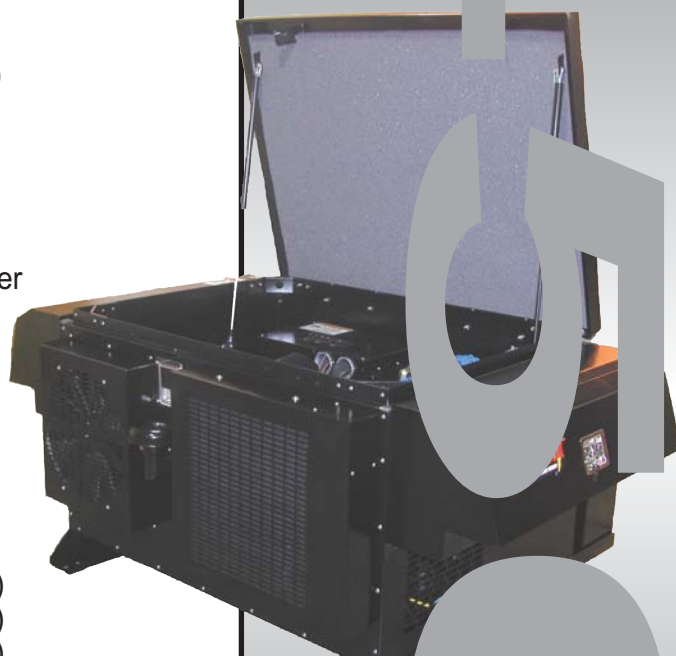

POWERBOX™
UNIVERSAL PORTABLE POWER SOURCE

Drop-In Pickup Trucks



Integrated Service Bodies



Drop-In Service Bodies



Products

| Part # | Drop-In Pickup Model |
|------------------------|---|
| PB450MSP-37-350 | Includes all standard features plus: Painted trim, lockable control panel, integrated 11 gallon fuel tank, lifting sling, 25' stick welding lead (stinger and ground clamp), integrated welder and 30 CFM compressor max. 145 PSI. |
| PB450MSP-70-350 | Includes all standard features plus: Painted trim, lockable control panel, integrated 11 gallon fuel tank, lifting sling, 25' stick welding lead (stinger and ground clamp) and compressor upgrade: 65 CFM rotary screw max. 145 PSI. Welder must be mounted remotely. |

| Part # | Integrated Service Body Model* |
|------------------------|---|
| PB450MSI-37-350 | Includes all standard features plus: Painted trim, lockable control panel, integrated slim line 15 gallon fuel tank, lifting sling, 25' stick welding lead (stinger and ground clamp), integrated welder and 30 CFM compressor max. 145 PSI. |
| PB450MSI-70-350 | Includes all standard features plus: Painted trim, lockable control panel, integrated slim line 15 gallon fuel tank, lifting sling, 25' stick welding lead (stinger and ground clamp) and compressor upgrade: 65 CFM rotary screw max. 145 PSI. Welder must be mounted remotely. |

*In order to ensure proper fit, please specify make and model of service body at time of order. The PowerBox™ installed, has 4" clearance from bottom of unit to truck bed. Custom base required if more clearance is needed.

| Part # | Service Body Drop-In Model** |
|------------------------|--|
| PB450MSD-37-350 | Includes all standard features plus: Painted trim, lockable control panel, integrated 11 gallon fuel tank, lifting sling, 25' stick welding lead (stinger and ground clamp), integrated welder and 30 CFM compressor max. 145 PSI. |
| PB450MSD-70-350 | Includes all standard features plus: Painted trim, lockable control panel, integrated 11 gallon fuel tank, lifting sling, 25' stick welding lead (stinger and ground clamp) and compressor upgrade: 65CFM rotary screw max. 145 PSI. Welder must be mounted remotely. |

**Includes custom base. In order to ensure proper fit, please specify make and model of service body at time of order. The PowerBox™ installed, has 12" - 18" clearance from bottom of unit to truck bed.

Accessories

| Part # | PowerBox™ Brand Accessories |
|-------------------|--|
| 14-1000-00 | 25' Stick welding lead extension. |
| SA-1070-00 | Integrated 12/24 volt, 90 Amp continuous, 800 Amp battery jumper booster w/ 17' cables standard. see pg 25 |

| Part # | Other Accessories |
|-------------------|--------------------------------------|
| 14-0195-00 | Miller® Spectrum® 375 Plasma Cutter. |

PowerBox™ 175MP

Generator • Compressor unit

Typical Applications:

The **PowerBox™ 175MP** is ideal for the general contractor, farmer/rancher, or plant maintenance technician that requires the ability to:

- Run power tools (i.e., saws, drills, grinders, lights, sanders, etc.)
- Run small air tools (i.e., impact wrenches up to 1/2", ratchets, grinders, nailers, etc.)

Engine:

- 12 hp Kohler® Command CS12 gasoline, air-cooled

Maximum Available Power:

- (60 Hz) 10 KVA alternator
- Maximum Output 7,500 watts
- 110v AC - Single Phase 7,500 watts (20 Amp)
- 230v AC - Single Phase 7,500 watts (30 Amp)

Electrical Outlets:

- 230v Single Phase (20 Amp)
- Two 110v (15 Amp) duplex GFCI receptacles

Air Compressor:

- 2 pumps 13 CFM @ 100 PSI
- Maximum 150 PSI available
- 5 gallon air storage tank
- One (1) 1/4" regulated outlet

Dimensions:

- Height: 30"
- Width: 28"
- Length: 44"

Weight:

- 525 lbs.



Utility Vehicles



Drop-In Pickup Trucks



Utility Vehicles



Products

| Part # | Drop-In Model |
|----------------|---|
| PB175MP | Includes all standard features plus: Painted trim, lockable lid, 6 gallon fuel tank and 13 CFM air compressors. |

PowerBox™ 240MP

Welder • Generator • Compressor unit

Typical Applications:

The **PowerBox™240MP** is ideal for the general contractor, farmer/rancher, or plant maintenance technician that requires the ability to:

- Run power tools (i.e., saws, drills, grinders, lights, sanders, etc.)
- Run small air tools (i.e., impact wrenches up to 1/2", ratchets, grinders, nailers, etc.)
- Perform light welding repair and fabrication

Engine:

- 12 hp Kohler® Command CS12 gasoline, air-cooled

Output Range

- DC-CC = 50 - 175 Amps

Maximum Available Power:

- (60 Hz) 5.5 KVA alternator
- Maximum Output 5,500 watts
- 110v AC - Single Phase 5,500 watts (20 Amp)
- 230v AC - Single Phase 5,500 watts (30 Amp)

Electrical Outlets:

- 230v Single Phase (20 Amp)
- Two 110v (15 Amp) GFCI duplex receptacles

Air Compressor:

- 2 pumps 13 CFM @ 100 PSI
- Maximum 150 PSI available
- 5 gallon air storage tank
- One (1) 1/4" regulated outlet

Dimensions:

- Height: 30"
- Width: 28"
- Length: 44"

Weight:

- 580 lbs.

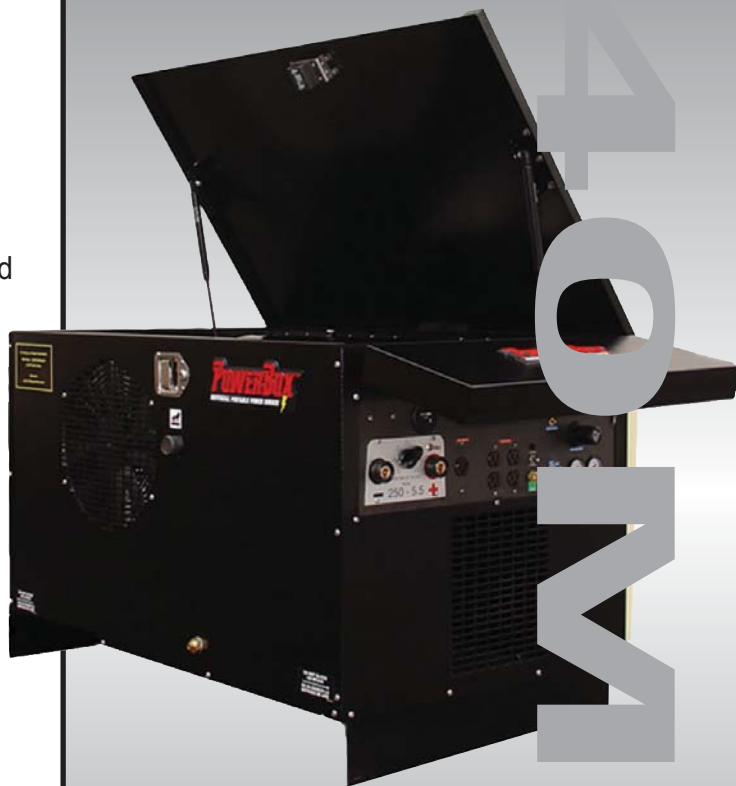

POWERBOX™
UNIVERSAL PORTABLE POWER SOURCE

Utility Vehicles



Drop-In Pickup Trucks



Utility Vehicles



Products

| Part # | Drop-In Model |
|----------------|---|
| PB240MP | Includes all standard features plus: Painted trim, lockable lid, 6 gallon fuel tank, integrated welder, 25' stick welding lead (stinger and ground clamp) and 13 CFM air compressors. |

Accessories

| Part # | Drop-In Model |
|-------------------|-----------------------------------|
| 14-1000-00 | 25' Stick welding lead extension. |

PowerBox™

800 Amp Battery Booster

A dead battery can ruin your day if you are not prepared. Now you can provide your PowerBox™ with even more versatility through the addition of an **800 Amp Battery Booster** unit.

The **800 Amp Battery Booster** is compact in structure and designed to be powered by your existing PowerBox™ unit. The booster bolts directly to the PowerBox™ or can be mounted remotely.

The booster is engineered for ease of operation and is powerful enough (with high cranking assist of 800 Amps) to start numerous vehicles between charges.

Features:

- Integrated 12/24 volt, 90 Amp continuous output.
- Large amperage allows users to start the heaviest of vehicles and/or equipment.
- Built in safety mechanism prevents live cables from being connected to a “dead” battery or accidental contact with other metal surfaces.
- Durable, weather resistant casing and control panel.
- 17' heavy duty cables with serrated jaws, tightly grip all top and side post terminals.
- Twist-lock connections at booster unit.
- Commercial grade components.
- Maximum Open Circuit Voltage (OCV)=19.2v (in 12v mode), 31v (in 24v mode).

Typical Applications:

The **800 Amp Battery Booster** is an ideal PowerBox™ accessory for anyone (including construction, farms, salvage/scrap yards, military, municipalities, vehicle/equipment fleets, and rental facilities, etc.) who require the ability to:

- Jump start cars, trucks, earth moving equipment, tractors and agricultural equipment, buses, etc.

Dimensions:

- Height: 22” Width: 8” Length: 48”



Control Panel



Direct Mounting



Remote Mounting



PowerBox™

Integrated Hydraulic Circuit

- Powers standard crane circuits (8 GPM / 2000PSI)
- Powers hydraulic tools, pumps, etc. (6 GPM / 3000 PSI)



Hydraulic reservoir located on back of PowerBox™.



Tool circuit and crane circuit hydraulic connectors.



Integrated control panel with hydraulics.

POWERBOX™

UNIVERSAL PORTABLE POWER SOURCE 



Dynamic Power Source, LLC
1-877-693-7269

975 Progress Blvd. New Albany, IN 47150
www.187POWERBOX.com