



Great Plains
Manufacturing, Inc.

Seed, Small Seeds and Fertilizer Rate Charts

The following pages are to assist in the proper setting of seeding and fertilizer rates for the 12, 15 and 20 ft. Three-Point drill. The rates indicated in the charts are approximate values. To assure the most accurate seeding rate it is recommended that the drill be calibrated for the desired seed at the time of planting.

Table of Contents

Seeding Rate3
Shift gearbox drive type3
Set Seed-Rate Handle3
Position Seed-Cup Doors4
Check Seeding Rate4
Seed Rate Chart5
Small Seeds Attachment8
Small Seeds Rate Chart8
Fertilizer Meter Rate9
Fertilizer Rate Chart9
Density Conversion Chart9

Seeding Rate

Calibrating the seeding rate requires four steps: shifting the gearbox, setting the seed-rate handle, positioning the seed-cup doors, and checking the seeding rate.

Refer to the seed-rate charts starting on page 5. These charts list the proper drive types and seed-rate handle settings for various seeds and seeding rates.

The seed-rate charts are based on cleaned, untreated seed of average size and test weight. The rates are based on 9.5L x 15 rib implement gauge-wheel tires on the 12- and 15-foot drills and 11L x 15 rib implement tires on the 20-foot drill. Many factors affect seeding rates including foreign material, seed treatment, seed size, field conditions, tire pressure and test weight. You likely will need to make minor adjustments. Set and check the seeding rate using the procedures below, then re-adjust the rate as necessary.

Before setting the seeding rate, rotate the drive gauge wheels. Check that seed cups and drive are working properly and free from foreign material.

Shift gearbox drive type

Refer to Figure 1

Refer to the seed-rate charts for the correct drive type—1, 2, 3 or 4—for your desired seeding rate. Move the selector handle on the gearbox until the correct number appears in the handle window. Rotate the tires a few turns to make sure the gearbox has engaged.

NOTE: If your drill has more than one gearbox, make sure both are shifted to the same drive type.

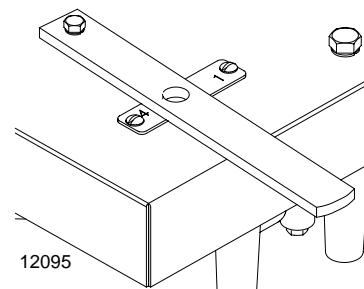

Figure 1
Seed Rate Gearbox

Gearbox Ratios:
Drive Type 2 is 2.06 Times Faster Than 1
Drive Type 3 is 3.08 Times Faster Than 1
Drive Type 4 is 5.03 Times Faster Than 1

Set Seed-Rate Handle

Refer to Figure 2

Position handle for each drill box to setting indicated on chart. To adjust, loosen the wing nut under the handle. Slide handle past desired setting, then move handle back until indicator lines up with correct setting. Retighten wing nut.

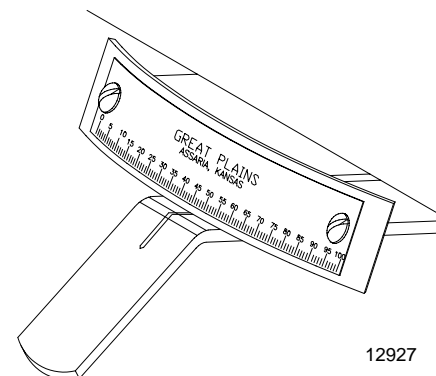

Figure 2
Seed-Rate Handle

Position Seed-Cup Doors

Refer to Figure 3

For wheat and other small seeds, move seed-cup-door handles to the highest position. For soybeans and other large seeds, lower handles to the second position. If excessive seed cracking occurs, lower handles to the third position. For seed-cup clean out, move handles to the fourth, wide-open position. Make sure all handles are in the same position before drilling.

Check Seeding Rate

- a. Record weight of an empty container large enough to hold seed metered for one acre.
- b. Place several pounds of seed over three seed cups on an outside end of drill box. Pull seed tubes off these three openers.
- c. Raise drill off the ground. If using a hitch, insert transport lock pins or turn 90° hydraulic lock valve, depending on hitch style.
- d. Turn drive gauge wheel a few turns to fill cups with seed. Turn wheel until seed drops to the ground from all three cups.
- e. Place a container under the three seed tubes to gather seed as it is metered.
- f. Turn drive gauge wheel for one acre (450 rotations on a 12-foot drill, 364 rotations on a 15-foot drill, or 283 rotations on a 20-foot drill). Check that the three seed cups have plenty of seed coming into them.
- g. Weigh the metered seed. Subtract initial weight of the empty container. Divide by three for the amount metered by each seed cup, then multiply by the number of drill openers for the pounds-per-acre seeding rate. If this figure is different than desired, adjust seed-rate handle and recheck the rate.

NOTE: If your results vary greatly from the charts, you may want to repeat the calibration procedure.

- h. When drilling, note acres drilled, amount of seed added and level of seed in drill box. If you are seeding more or less than desired, adjust seeding rate slightly to compensate for field conditions.

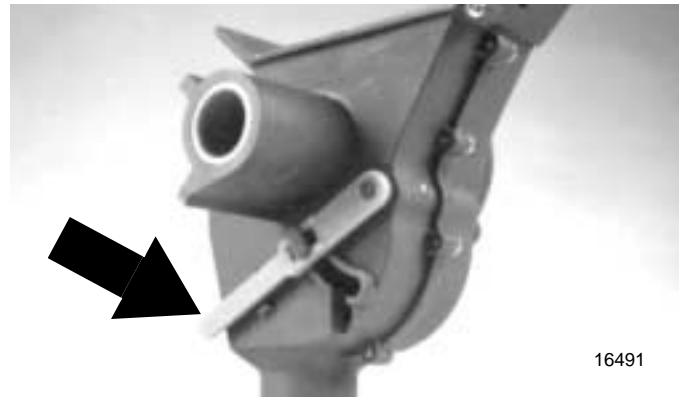

16491

Figure 3
Seed-Cup-Door Handle

Seed Rate Chart (pounds per acre)

Setting number	0	5	10	15	20	25	30	35	40	45	50	55	60	65	70	75	80	85	90	95	100	
Alfalfa or Rape Drive Type 1 (Based on 60#/bu)	Row Spacing 6"	2	6	8	12	15	19	23	27	32	37	41	45	50	54	59	63	69	74	79	82	84
	7"	2	5	7	10	13	16	20	23	27	32	35	38	43	47	51	54	59	63	68	70	72
	7.5"	2	4	7	10	12	15	18	22	25	29	33	36	40	43	47	51	55	59	63	65	67
	8"	2	4	6	9	12	14	17	20	24	28	31	34	37	41	44	47	52	55	60	61	63
	10"	1	3	5	7	9	12	14	16	19	22	25	27	30	33	35	38	41	44	48	49	50
Barley Drive Type 1 (Based on 51#/bu)	Row Spacing 6"	2	5	8	11	14	18	22	26	30	35	39	43	48	53	57	62	66	69	73	73	74
	7"	2	4	7	9	12	16	19	22	26	30	33	37	41	45	49	53	56	59	62	63	63
	7.5"	2	4	6	9	12	15	18	21	24	28	31	35	38	42	46	49	52	55	58	59	59
	8"	1	3	6	8	11	14	17	20	23	26	29	32	36	40	43	46	49	52	54	55	55
	10"	1	3	5	6	9	11	13	16	18	21	23	26	29	32	34	37	39	42	44	44	44
Barley Drive Type 2 (Based on 51#/bu)	Row Spacing 6"	4	9	16	22	30	37	45	54	62	71	76	87	96	104	114	123	133	142	152	154	156
	7"	3	7	14	19	26	32	39	46	53	61	68	75	82	89	97	105	114	122	130	132	134
	7.5"	3	7	13	17	24	30	36	43	49	57	64	70	77	83	91	98	106	114	121	123	125
	8"	3	7	12	16	22	28	34	40	46	53	60	65	72	78	85	92	100	107	114	116	117
	10"	2	5	10	13	18	22	27	32	37	43	48	52	58	63	68	74	80	85	91	92	94
Barley Drive Type 4 (Based on 51#/bu)	Row Spacing 6"	9	21	39	53	73	90	110	131	151	174	194	213	234	255	278	300	325	348	371	377	382
	7"	7	18	33	45	63	78	95	113	130	149	166	182	201	218	238	257	278	299	318	323	328
	7.5"	7	17	31	42	58	72	88	105	121	139	155	170	188	204	222	240	260	279	297	301	306
	8"	6	16	29	40	55	68	83	99	113	130	146	160	176	191	208	225	244	261	278	282	287
	10"	5	13	23	32	44	54	66	79	91	104	117	128	141	153	167	180	195	209	222	226	230
Buck Wheat Drive Type 3 (Based on 48#/bu)	Row Spacing 6"	0	11	21	29	42	52	65	78	92	107	123	136	150	165	180	195	209	224	240	242	245
	7"	0	10	18	25	36	45	56	67	79	92	106	116	129	142	154	168	179	192	205	207	210
	7.5"	0	9	17	24	34	42	52	62	74	85	99	109	120	132	144	156	167	179	192	194	196
	8"	0	8	16	22	31	39	49	59	69	80	92	102	113	124	135	147	157	168	180	181	183
	10"	0	7	13	18	25	31	39	47	55	64	74	81	90	99	108	117	126	134	144	145	147
Flax or Sudan Drive Type 1 (Based on 55#/bu)	Row Spacing 6"	0	4	8	12	16	20	24	28	33	37	42	46	50	54	59	65	70	76	82	83	85
	7"	0	3	7	10	14	17	21	24	28	32	36	39	43	47	51	55	60	65	70	71	73
	7.5"	0	3	7	9	13	16	19	23	26	30	34	37	40	44	47	52	56	61	66	67	68
	8"	0	3	6	9	12	15	18	21	25	28	31	34	37	41	44	49	52	57	61	62	64
	10"	0	2	5	7	10	12	15	17	20	22	25	27	30	33	35	39	42	45	49	50	51
Millet Drive Type 1 (Based on 60#/bu)	Row Spacing 6"	1	5	8	12	16	20	23	27	32	36	40	44	49	52	57	62	66	71	76	77	78
	7"	1	4	7	10	13	17	20	23	27	31	34	38	42	45	49	53	57	61	65	66	67
	7.5"	1	4	7	9	13	16	19	22	25	29	32	35	39	42	46	49	53	57	61	62	63
	8"	1	4	6	9	12	15	18	20	24	27	30	33	36	39	43	46	50	53	57	58	59
	10"	1	3	5	7	9	12	14	16	19	21	24	26	29	32	34	37	40	43	46	46	47
Milo Drive Type 1 (Based on 64#/bu)	Row Spacing 6"	0	5	9	13	18	23	28	34	39	45	52	57	63	69	75	81	87	92	98	100	102
	7"	0	4	8	11	15	19	24	29	34	38	44	49	54	59	64	69	74	79	84	86	88
	7.5"	0	4	7	10	14	18	22	27	31	36	41	45	50	55	60	65	69	73	78	80	82
	8"	0	4	7	10	13	17	21	25	29	34	39	43	47	52	56	61	65	69	73	75	77
	10"	0	3	5	8	11	14	17	20	23	27	31	34	38	41	45	49	52	55	59	60	61
Oats Drive Type 3 (Based on 37#/bu)	Row Spacing 6"	0	5	12	17	24	32	39	47	55	63	72	80	88	96	105	113	121	130	139	140	140
	7"	0	5	10	15	21	27	33	40	47	54	62	68	76	82	90	97	104	111	119	120	120
	7.5"	0	4	10	14	19	25	31	37	44	51	58	64	70	77	84	90	97	104	111	112	112
	8"	0	4	9	13	18	24	29	35	41	47	54	60	66	72	78	85	91	97	104	105	105
	10"	0	3	7	10	14	19	23	28	33	38	43	48	53	58	63	68	73	78	83	84	84

Setting number		0	5	10	15	20	25	30	35	40	45	50	55	60	65	70	75	80	85	90	95	100	
Peas Drive Type 3 (Based on 61#/bu)	Row Spacing	6"	0	0	19	34	52	69	84	102	119	137	154	169	186	202	218	235	251	266	281	283	284
		7"	0	0	16	29	45	59	72	87	102	118	132	145	160	173	187	202	215	228	241	243	244
		7.5"	0	0	15	27	42	55	67	82	95	110	123	136	149	161	175	188	201	213	225	226	227
		8"	0	0	14	26	39	52	63	76	89	103	116	127	140	151	164	177	188	200	211	212	213
		10"	0	0	11	20	31	41	50	61	71	82	93	102	112	121	131	141	151	160	169	170	171
Pinto Beans Drive Type 1 (Based on 61#/bu)	Row Spacing	6"	0	0	9	13	17	24	30	35	41	47	53	58	64	69	74	81	85	91	97	96	96
		7"	0	0	7	11	15	20	25	30	35	40	45	50	55	59	64	69	73	78	83	83	83
		7.5"	0	0	7	10	14	19	24	28	33	38	42	47	51	55	60	65	68	73	77	77	77
		8"	0	0	6	10	13	18	22	27	31	35	40	44	48	52	56	61	64	68	72	72	72
		10"	0	0	5	8	10	14	18	21	25	28	32	35	38	41	45	49	51	54	58	58	58
Rice Short Grain Drive Type 3 (Based on 43#/bu)	Row Spacing	6"	3	11	18	28	38	46	56	64	73	84	96	107	117	128	139	148	167	165	174	174	174
		7"	3	9	16	24	33	39	48	54	63	72	82	92	101	110	119	127	134	142	149	149	149
		7.5"	2	9	14	23	31	37	44	51	59	67	77	85	94	102	111	118	125	132	139	139	139
		8"	2	8	14	21	29	34	42	48	55	63	72	80	88	96	104	111	117	124	131	131	131
		10"	2	7	11	17	23	27	33	38	44	50	57	64	70	77	83	89	94	99	105	105	105
Rice Short Grain Drive Type 4 (Based on 43#/bu)	Row Spacing	6"	5	18	29	46	63	74	91	104	120	137	156	174	191	209	226	241	255	269	284	284	284
		7"	4	15	25	40	54	64	78	89	103	117	134	149	164	179	194	207	219	231	243	243	243
		7.5"	4	14	24	37	50	60	72	83	96	109	125	139	153	167	181	193	204	215	227	227	227
		8"	4	13	22	35	47	56	68	78	90	102	117	131	143	156	169	181	191	202	213	213	213
		10"	3	11	18	28	38	45	54	62	72	82	94	105	115	125	136	145	153	162	170	170	170
Rice Long Grain Drive Type 1 (Based on 47#/bu)	Row Spacing	6"	0.0	1.4	4.4	7.4	10.4	13.7	16.8	19.8	22.9	26.1	31.6	32.1	35.1	38.1	41.1	44.3	46.8	49.4	51.5	52.9	53.9
		7"	0.0	1.2	3.8	6.3	8.9	11.7	14.4	17.0	19.7	22.4	27.1	27.5	30.1	32.7	35.2	38.0	40.1	42.4	44.2	45.3	46.2
		7.5"	0.0	1.1	3.6	5.9	8.3	10.9	13.5	15.9	18.4	20.9	25.3	25.7	28.1	30.5	32.9	35.4	37.5	39.5	41.2	42.3	43.1
		8"	0.0	1.1	3.3	5.5	7.8	10.2	12.6	14.9	17.2	19.6	23.7	24.1	26.3	28.6	30.8	33.2	35.1	37.1	38.6	39.7	40.4
		10"	0.0	0.8	2.7	4.4	6.2	8.2	10.1	11.9	13.8	15.7	19.0	19.3	21.1	22.9	24.7	26.6	28.1	29.7	30.9	31.7	32.3
Rice Long Grain Drive Type 2 (Based on 47#/bu)	Row Spacing	6"	0	3	9	15	21	28	35	41	47	54	65	66	72	78	85	91	96	102	106	109	111
		7"	0	3	8	13	18	24	30	35	40	46	56	57	62	67	72	78	83	87	91	93	95
		7.5"	0	2	7	12	17	23	28	33	38	43	52	53	58	63	68	73	77	81	85	87	89
		8"	0	2	7	11	16	21	26	31	35	40	49	50	54	59	63	68	72	76	80	82	83
		10"	0	2	6	9	13	17	21	25	28	32	39	40	43	47	51	55	58	61	64	65	67
Rice Long Grain Drive Type 3 (Based on 47#/bu)	Row Spacing	6"	0	0	13	22	32	42	53	61	71	81	90	98	107	116	125	135	144	153	161	167	173
		7"	0	0	11	19	27	36	45	53	61	69	77	84	91	99	107	116	124	131	138	143	148
		7.5"	0	0	11	17	25	34	42	49	57	65	72	79	85	92	100	108	116	123	129	134	138
		8"	0	0	10	16	24	31	40	46	53	61	67	74	80	87	94	101	108	115	121	125	130
		10"	0	0	8	13	19	25	32	37	42	49	54	59	64	69	75	81	87	92	97	100	104
Rice Long Grain Drive Type 4 (Based on 47#/bu)	Row Spacing	6"	0	0	22	35	52	68	86	100	115	132	146	160	174	188	204	220	235	250	263	273	282
		7"	0	0	18	30	44	59	74	86	99	113	125	137	149	161	175	188	202	214	225	234	242
		7.5"	0	0	17	28	41	55	69	80	92	105	117	128	139	151	163	176	188	200	210	218	226
		8"	0	0	16	27	39	51	65	75	87	99	110	120	130	141	153	165	177	187	197	204	211
		10"	0	0	13	21	31	41	52	60	69	79	88	96	104	113	123	132	141	150	158	164	169
Rye Drive Type 1 (Based on 57#/bu)	Row Spacing	6"	0	3	8	13	19	24	28	35	41	47	53	58	63	68	74	81	87	94	101	102	102
		7"	0	2	7	11	16	21	24	30	35	40	45	50	54	59	63	69	74	80	87	87	88
		7.5"	0	2	6	10	15	19	22	28	33	38	42	46	50	55	59	64	69	75	81	81	82
		8"	0	2	6	10	14	18	21	26	31	35	40	44	47	51	55	60	65	70	76	76	77
		10"	0	2	5	8	11	14	17	21	24	28	32	35	38	41	44	48	52	56	61	61	61

Setting number		0	5	10	15	20	25	30	35	40	45	50	55	60	65	70	75	80	85	90	95	100	
Soybeans Drive Type 1 (Based on 58#/bu)	Row Spacing	6"	0	3	8	13	19	23	29	34	39	45	49	55	61	66	71	77	82	87	93	93	93
		7"	0	2	7	11	17	20	25	29	34	38	42	48	52	57	61	67	70	75	79	80	80
		7.5"	0	2	6	11	15	19	23	27	31	36	40	44	49	53	57	62	65	70	74	74	75
		8"	0	2	6	10	15	17	22	25	29	34	37	42	46	50	54	58	61	65	69	70	70
		10"	0	2	5	8	12	14	17	20	24	27	30	33	37	40	43	46	49	52	56	56	56
Soybeans Drive Type 2 (Based on 58#/bu)	Row Spacing	6"	0	6	16	27	40	48	59	69	80	92	102	114	125	136	147	158	167	179	190	191	192
		7"	0	5	14	23	34	41	51	59	69	79	87	98	107	117	126	136	144	153	163	164	164
		7.5"	0	5	13	22	32	38	47	55	64	73	81	91	100	109	118	127	134	143	152	153	153
		8"	0	4	12	20	30	36	44	52	60	69	76	86	94	102	110	119	126	134	143	143	144
		10"	0	4	10	16	24	29	35	42	48	55	61	68	75	82	88	95	101	107	115	115	115
Soybeans Drive Type 3 (Based on 58#/bu)	Row Spacing	6"	0	12	23	40	60	71	89	101	116	131	148	164	181	196	214	228	248	265	284	284	284
		7"	0	10	19	35	51	61	76	87	100	113	127	141	155	168	183	195	213	227	244	243	244
		7.5"	0	9	18	32	48	57	71	81	93	105	119	131	145	157	171	182	199	212	227	227	227
		8"	0	9	17	30	45	53	67	76	87	99	111	123	136	147	160	171	186	199	213	213	213
		10"	0	7	14	24	36	42	53	61	70	79	89	98	108	118	128	137	149	159	170	170	170
Soybeans Drive Type 4 (Based on 58#/bu)	Row Spacing	6"	0	19	37	66	97	115	145	165	190	214	241	267	295	320	348	371	405	433	463	463	464
		7"	0	16	31	56	83	99	124	141	163	184	207	229	253	274	299	318	347	371	397	397	397
		7.5"	0	15	29	53	78	92	116	132	152	171	193	214	236	256	279	297	324	346	370	371	371
		8"	0	14	28	49	73	86	109	124	142	161	181	200	221	240	261	278	304	324	347	347	348
		10"	0	11	22	40	58	69	87	99	114	128	145	160	177	192	209	223	243	260	278	278	278
Sun flowers Drive Type 1 (Based on 28#/bu)	Row Spacing	6"	0	0	2	4	6	8	11	13	15	18	20	23	25	27	30	32	34	36	38	39	41
		7"	0	0	2	4	5	7	9	11	13	15	17	19	21	23	25	27	29	31	33	34	35
		7.5"	0	0	2	3	5	7	9	10	12	14	16	18	20	22	24	26	27	29	31	32	33
		8"	0	0	2	3	5	6	8	10	12	13	15	17	19	21	22	24	26	27	29	30	31
		10"	0	0	1	3	4	5	6	8	9	11	12	14	15	16	18	19	20	22	23	24	24
Wheat Drive Type 2 (Based on 64#/bu)	Row Spacing	6"	0	13	22	30	40	50	57	70	80	91	105	115	127	140	152	164	177	190	203	205	206
		7"	0	11	19	26	34	43	49	60	69	78	90	99	109	120	131	141	152	163	174	176	177
		7.5"	0	10	18	24	32	40	46	56	64	73	84	92	102	112	122	131	142	152	162	164	165
		8"	0	9	17	23	30	37	43	52	60	69	79	86	96	105	114	123	133	143	152	153	154
		10"	0	8	13	18	24	30	34	42	48	55	63	69	76	84	91	99	106	114	122	123	124
Wheat Drive Type 3 (Based on 64#/bu)	Row Spacing	6"	0	16	31	45	60	74	88	104	120	137	153	168	186	202	220	240	256	274	290	297	299
		7"	0	14	26	38	51	64	75	89	103	117	131	144	159	174	189	206	219	235	248	254	256
		7.5"	0	13	25	36	48	59	70	83	96	109	123	134	149	162	176	192	205	219	232	237	239
		8"	0	12	23	34	45	56	66	78	90	102	115	126	139	152	165	180	192	205	217	223	224
		10"	0	10	18	27	36	45	53	62	72	82	92	101	111	121	132	144	154	164	174	178	179
Wheat Grass Drive Type 1 (Based on 23#/bu)	Row Spacing	6"	0	1	2	3	4	5	6	7	8	10	11	12	13	14	15	17	18	19	19	21	21
		7"	0	1	2	3	4	4	5	6	7	8	9	10	11	12	13	14	15	17	16	18	18
		7.5"	0	1	2	2	3	4	5	6	7	8	9	10	11	11	12	13	14	15	15	17	17
		8"	0	1	2	2	3	4	5	6	6	7	8	9	10	11	12	13	13	15	14	16	16
		10"	0	1	1	2	3	3	4	4	5	6	7	7	8	9	9	10	11	12	11	13	13

Small Seeds Attachment

To set and calibrate the seeding rate on the optional small seeds attachment, follow these steps.

1. Set the seed-rate handle on the small seeds attachment as indicated by the *Small Seeds Rate Chart*, this page.

2. Calibrate the small seeds attachment to your material by following the steps under *Check Seeding Rate*, page 4.

Small Seeds Rate Chart

Setting Number		5	10	15	20	25	30	35	40	45	50	55	60	65	70	75	80	85	90	95	100	
Kentucky Blue Grass, Fescue, Annual Rye Grass	Row Spacing	6"	0	.2	1.2	1.9	2.7	3.3	4.1	4.6	5.2	5.8	6.3	6.8	7.3	7.8	8.3	8.8	9.2	9.7	10.0	10.5
	7"	0	.2	1.0	1.6	2.3	2.8	3.5	4.0	4.5	5.0	5.4	5.9	6.3	6.7	7.1	7.5	7.9	8.0	8.6	9.0	
	7.5"	0	.2	.9	1.5	2.2	2.7	3.3	3.7	4.2	4.6	5.1	5.5	5.9	6.3	6.7	7.0	7.4	7.7	8.1	8.4	
	8"	0	.2	.9	1.4	2.0	2.5	3.0	3.5	3.9	4.3	4.8	5.1	5.5	5.9	6.2	6.6	6.9	7.5	7.5	7.9	
	10"	0	.1	.7	1.1	1.6	2.0	2.4	2.7	3.1	3.4	3.7	4.0	4.3	4.6	4.9	5.2	5.4	5.7	5.9	6.2	
Ladino Clover, Canary Grass, Timothy, Canola	Row Spacing	6"	0	1.1	2.1	3.3	4.7	6.1	7.6	9.2	10.7	12.2	13.8	15.5	17.0	18.5	20.3	21.7	23.4	25.4	27.3	29.2
	7"	0	.9	1.7	2.8	4.1	5.2	6.6	7.9	9.2	10.5	11.8	13.3	14.6	15.9	17.4	18.7	20.0	22.0	23.4	25.1	
	7.5"	0	.9	1.6	2.6	3.9	4.9	6.1	7.4	8.6	9.8	11.1	12.5	13.7	14.9	16.3	17.6	18.8	20.4	21.9	23.5	
	8"	0	.8	1.5	2.5	3.6	4.6	5.7	6.9	8.0	9.2	10.3	11.6	12.8	13.9	15.2	16.4	17.5	19.0	20.5	21.9	
	10"	0	.6	1.5	1.9	2.5	3.6	4.5	5.4	6.3	7.2	8.1	9.1	10.0	10.9	12.0	12.9	13.8	14.9	16.1	17.2	
Bermuda, Red Top, Unhulled Lespedeza, Sericia, Sand & Weeping Love Grass	Row Spacing	6"	0	.7	1.1	1.7	2.6	3.3	4.1	5.0	5.9	6.6	7.2	7.8	8.4	9.0	9.5	10.2	10.9	11.6	12.2	12.9
	7"	0	.6	.9	1.5	2.2	2.8	3.6	4.3	5.1	5.6	6.2	6.7	7.1	7.7	8.1	8.7	9.4	10.0	10.5	11.0	
	7.5"	0	.5	.9	1.4	2.1	2.6	3.3	4.0	4.7	5.3	5.8	6.3	6.7	7.2	7.6	8.2	8.8	9.3	9.8	10.4	
	8"	0	.5	.8	1.3	2.0	2.5	3.1	3.8	4.4	4.9	5.4	5.9	6.5	6.7	7.1	7.6	8.2	8.7	9.2	9.7	
	10"	0	.4	.6	1.0	1.5	1.9	2.4	3.0	3.5	3.9	4.2	4.6	4.9	5.3	5.6	6.0	6.4	6.8	7.2	7.6	
Red & Sweet Clover, Lespedeza Hulled	Row Spacing	6"	0	1.5	3.4	5.2	7.1	9.0	11.3	13.2	15.3	17.0	19.0	20.8	22.5	24.5	26.4	28.3	30.1	32.1	33.8	35.6
	7"	0	1.3	2.9	4.5	6.1	7.7	9.7	11.3	13.1	14.6	16.3	17.8	19.3	21.0	22.7	24.6	25.8	27.5	29.0	30.5	
	7.5"	0	1.2	2.7	4.2	5.7	7.2	9.1	10.6	12.3	13.7	15.3	16.7	18.1	19.7	21.2	22.7	24.2	25.8	27.2	28.6	
	8"	0	1.1	2.5	3.9	5.3	6.7	8.5	9.9	11.5	12.8	14.3	15.6	16.9	18.3	19.8	21.2	22.6	24.1	25.4	26.7	
	10"	0	.9	2.0	3.1	4.2	5.3	6.7	7.8	9.0	10.0	11.2	12.2	13.3	14.4	15.6	16.6	17.8	18.9	19.9	20.9	
Bird's-foot Trefoil, Sudan	Row Spacing	6"	0	1.7	3.3	5.2	6.8	8.7	10.7	12.7	14.7	16.8	19.2	21.2	23.4	25.6	28.0	29.9	32.1	34.2	36.3	38.4
	7"	0	1.5	2.8	4.5	5.8	7.5	9.2	10.9	12.5	14.4	16.5	18.2	20.0	21.9	24.0	25.6	27.5	29.0	31.1	32.9	
	7.5"	0	1.4	2.6	4.2	5.4	7.0	8.6	10.2	11.9	13.5	15.4	17.0	18.8	20.5	22.5	24.0	25.8	27.6	29.1	30.9	
	8"	0	1.3	2.5	3.9	5.1	6.6	8.1	9.5	11.0	12.6	14.4	15.9	17.5	19.2	21.0	22.4	24.1	25.7	27.2	28.8	
	10"	0	1.0	1.9	3.1	4.0	5.1	6.3	7.5	8.6	9.9	11.3	12.5	13.8	15.1	16.5	17.6	18.9	20.2	21.4	22.7	
Orchard Grass	Row Spacing	6"	0	0	.3	.7	.9	1.3	1.5	2.0	2.4	2.8	3.3	3.5	3.9	4.4	4.8	5.0	5.5	5.7	6.1	6.3
	7"	0	0	.2	.6	.7	1.1	1.3	1.7	2.1	2.4	2.8	3.0	3.4	3.7	4.1	4.3	4.7	5.0	5.2	5.4	
	7.5"	0	0	.2	.5	.7	1.1	1.2	1.6	1.9	2.3	2.6	2.8	3.2	3.5	3.9	4.0	4.4	4.6	4.9	5.1	
	8"	0	0	.2	.5	.7	1.0	1.1	1.5	1.8	2.1	2.5	2.6	2.9	3.3	3.6	3.8	4.1	4.3	4.6	4.8	
	10"	0	0	.1	.4	.5	.8	.9	1.2	1.4	1.7	1.9	2.1	2.3	2.6	2.8	3.0	3.2	3.3	3.6	3.7	
Millet, Reed Canary	Row Spacing	6"	.4	1.4	2.4	3.5	4.4	5.5	6.5	7.5	8.5	9.5	10.5	11.5	12.5	13.6	14.6	15.6	16.6	17.6	18.5	19.0
	7"	.4	1.2	2.1	3.0	3.8	4.7	5.6	6.4	7.3	8.1	9.0	9.9	10.7	11.6	12.5	13.3	14.2	15.1	15.9	16.1	
	7.5"	.3	1.2	2.0	2.8	3.6	4.4	5.2	6.0	6.8	7.6	8.4	9.3	10.1	10.9	11.7	12.5	13.3	14.1	14.9	15.1	
	8"	.3	1.1	1.8	2.6	3.3	4.1	4.9	5.6	6.4	7.1	7.9	8.6	9.4	10.2	10.9	11.7	12.4	13.2	13.9	14.1	
	10"	.3	.8	1.4	2.0	2.6	3.2	3.8	4.4	5.0	5.6	6.2	6.8	7.4	8.0	8.6	9.2	9.8	10.4	10.9	11.5	
Alfalfa, Red Alsike, Crimson Clover	Row Spacing	6"	0	2.2	3.5	4.8	6.0	7.5	8.7	9.8	11.2	12.5	13.8	15.1	16.4	17.5	18.6	20.2	21.4	22.9	24.0	25.2
	7"	0	1.9	3.0	4.1	5.1	6.4	7.5	8.4	9.5	10.8	11.8	12.9	14.0	15.0	16.3	17.3	18.3	20.0	20.6	21.6	
	7.5"	0	1.8	2.8	3.9	4.8	6.0	7.0	7.9	9.0	10.0	11.1	12.1	13.2	14.0	15.3	16.2	17.2	18.3	19.3	20.3	
	8"	0	1.6	2.6	3.6	4.5	5.6	6.6	7.4	8.4	9.4	10.3	11.3	12.3	13.1	13.0	15.2	16.1	17.1	18.0	18.9	
	10"	0	1.3	2.1	2.8	3.5	4.4	5.1	5.8	6.6	7.4	8.1	8.9	9.7	10.3	11.2	11.9	12.6	13.4	14.2	14.9	

Fertilizer Meter Rate

Fertilizer application rates will vary with fertilizer type, density and particle size. Relative humidity and field conditions can also affect application rates. The chart on this page is based on material with a density of 65 pounds per cubic foot (1.04 kg/L) and average particle size. Initially set the rate according to the charts, then calibrate the drill to your material as described below.

If your drill has two boxes, remember to repeat the following steps for each drill box.

1. Raise the drill with the tractor hydraulics so the drive wheels are off the ground. Rotate the drive wheels to see that the metering system is working properly and free from foreign material.
2. From the chart, find the setting number for your row spacing and desired application rate. Rotate the gate adjustment knob to the number obtained from the chart.

IMPORTANT: The fertilizer rate chart is for granular fertilizer with a density of 65 pounds per cubic foot (1.04 kg/L). If you are applying fertilizer with a different density, use the density conversion chart.

3. Check that your gauge-wheel tires are the correct size (9.5L x 15 for 12- and 15-foot drills and 11L x 15 for 20-foot drills) and properly inflated. Refer to *Tire Inflation Chart*, "Appendix," in the Operator's manual.

4. Record the weight of an empty container large enough to hold the fertilizer metered for one acre.
5. Place several pounds of fertilizer over three fertilizer feed cups on the outside end of the drill box. Pull the fertilizer tubes off of these three openers.
6. Turn the gauge wheels a few turns to fill the feed cups with material. Continue to turn until fertilizer drops to the ground from all three tubes.
7. Place a container under the three tubes to gather metered fertilizer.
8. Turn the gauge wheel until for one acre (450 tire rotations on a 12-foot drill, 364 on a 15-foot drill or 283 rotations on a 20-foot drill). Check that the three feed cups have plenty of fertilizer coming into them.
9. Weigh the metered material. Subtract the initial weight of the empty container. Divide by three. Multiply by the number of openers on your drill to determine total pounds-per-acre metered. If this figure is different than desired, reset adjustment knob accordingly.

NOTE: You may want to repeat the calibration procedure if your results vary greatly from the chart.

10. When drilling, check the rate by noting acres drilled, amount of fertilizer added to drill and level of material in drill box. If you are applying more or less than desired, adjust the metering rate slightly to compensate for field conditions.

Fertilizer Rate Chart (pounds per acre)

Setting number	15	20	25	30	35	40	45	50	55	60	65	70	75	80	85	90	95	100	
Row Spacing	6"	13	25	48	67	89	112	131	154	173	197	218	234	261	279	292	303	306	308
	7"	13	23	41	57	78	95	111	131	148	165	184	199	221	235	246	256	259	261
	7.5"	11	20	38	54	72	89	105	123	138	157	174	187	209	223	234	242	245	247
	8"	11	20	36	50	69	84	98	115	130	146	163	176	195	207	219	226	228	231
	10"	8	16	29	40	54	67	79	92	104	118	131	140	157	167	175	182	183	185

Density Conversion Chart

The fertilizer meter rate charts are based on fertilizer with a density of 65 pounds per cubic foot (1.04 kilograms per liter). If you are applying fertilizer of a different density, use the following table to convert application rate.

Density, lb/ft ³ (kg/l)	45.0 (0.72)	50.0 (0.80)	55.0 (0.88)	60.0 (0.96)	65.0 (1.04)	70.0 (1.12)	75.0 (0.87)	80.0 (0.81)
Conversion Factor	1.45	1.30	1.20	1.10	1.00	0.93	0.87	0.81

Example: Your fertilizer has a density of 75 pounds per cubic foot, and you want to apply 100 pounds per acre. Multiply the desired application rate by the conversion factor.

$$100 \times 0.87 = 87$$

Adjust drill to the setting closest to 87 pounds per acre.