

1 CONTENTS

		PAGE
2	FOREWORD	3
2.1	THE SIGN OF CAUTION	
3	TECHNICAL SPECIFICATIONS	3
4	SAFETY PRECAUTIONS	4
4.1	GENERAL SAFETY	4
4.2	TRANSPORT AND SITE-CHANGING	4
4.3	MAINTENANCE AND REPAIRS	5
4.4	HYDRAULIC SYSTEM	5
4.5	UNIVERSAL DRIVE SHAFT	6
5	LOCATION OF SAFETY DECALS AND COMPONENTS, SERIAL NUMBER PLATE	6-9
6	OPERATING ENVIRONMENT	10
6.1	OBJECT OF USAGE	10
6.2	APPLICATIONS	10
6.3	LIMITATIONS OF USE AND PROHIBITED USES	10
7	PRINCIPLE OF OPERATION	10
8	TRANSPORTATION, HANDLING AND STORAGE	11
8.1	TRANSPORTATION	11
8.2	HANDLING	11
8.3	STORAGE	11
8.4	SPECIFIC NOTES ON TRANSPORTATION SAFETY	11
9	TAKING A NEW MACHINE INTO USE	12
9.1	PREPARATIONS PRIOR TO OPERATING	12
9.2	DISCARDING THE EXPORT PACKAGING MATERIALS	12
9.3	ATTACHMENT TO A TRACTOR	12
9.4	PTO SHAFT	13
10	ADJUSTMENTS	14
10.1	KNIFE SETTING	14
10.2	FEED RATE ADJUSTMENT	15
11	USAGE	15
12	MAINTENANCE	16
12.1	CUTTING KNIFE SHARPENING	16
12.2	LUBRICATION	16
13	FAULT FINDING CHART	17
13.1	DEVELOPMENT OF FAULTS	17
14	TERMS OF WARRANTY	18
15	SCOPE OF RESPONSIBILITY	18
	SPARE PARTS SECTION	19-

2 FOREWORD

We thank you for your confidence in our product and also take this opportunity to wish you every success in your profession.

We would ask you to read and to memorize the operating hints and instructions outlaid in this manual. A full knowledge of the operation of the machine, together with correct adjustments and careful maintenance guarantee a full working safety and un-interrupted operation during busy working days.

It is of utmost importance that every aspect mentioned in this manual be fully understood and that the instructions are complied with without exceptions. If in doubt on any point, please do not hesitate to contact your dealer to clear it up.

We also hope that after acquainting yourself with the manual, you will take the trouble of returning the undersigned warranty certificate back to the manufacturer.



2.1 THE SIGN OF CAUTION

This symbol is used throughout the manual to denote operations where there is a risk of danger to the operator or any persons near the machine at the moment of carrying out the specified operation. The symbol is also used to denote any risk of danger which might befall environment or property.

3 TECHNICAL SPECIFICATIONS

Machine type	HJ 4 M	HJ 4 SLT
Cutter flange dia. cm	43	43
Cutter flange weight kg	45	45
Flange speed rpm	540-1000	540-1000
No. of cutter knives	3	3
Chip size mm	4-12	4-12
Stem dia. cm (max)	10	10
Cutting efficiency cu.m/h	2-6	2-6
Power requirement hp/kW	15-50/11-36	15-50/11-36
Weight of basic model kg	172	243
Height in transport		
Position cm	190	190
Feed orifice size cm	17 x 20	17x20
Feed mechanism	Manual Feed	Utilizing tractor hydraulic system feed
Packaging:	-Chipper chamber -Chute -Extension of chute -Discharge chute -Flap	-Chipper chamber -Chute -Feeders cover -Discharge chute

SPECIFICATIONS OF YOUR PARTICULAR CHIPPER:

Model _____
Serial No. _____
Year of manufact. _____



4 SAFETY PRECAUTIONS



4.1 GENERAL SAFETY NOTES

-**CLOTHING:** For the sake of personal safety use well-fitting clothing without any loose or hanging projecting sleeves etc. which might be caught in the running machinery.

-**OPERATING:** Before attempting to operate the machine, acquaint yourself fully with the attachment, controls and the operation of the machine.

-**CAUTION DECALS:** Always comply with all the cautions and instructions given on the various caution decals on the machine.

-**SAFETY EQUIPMENT:** The machine may only be used when all its safety shields and devices are in place and in a proper condition. For personal safety always wear a hard hat (a lumberjack type) plus hearing and eye protectors.

-**ATTACHMENT TO TRACTOR:** Take special caution when attaching the machine to or disengaging it from the tractor.

-**DRAWBAR LOAD:** Take into consideration the maximum allowed tractor drawbar and hydraulic hitch loadings.

-**PARKING:** Make certain that the machine cannot start to move by itself while parked between the working shifts.

-**SAFE DISTANCE:** Due to its operational principles, the machine has certain parts which cannot be fully safe-guarded. A safe distance must therefore be kept to these components while the machine is in operation. The operator must also take care not to allow any outsiders approach these points on the machine.

-**OPERATIONAL NOTES:** While the machine is operating, no persons, except the operator, must be allowed to remain in vicinity of the machine.

1. Never enter the space between the tractor and the chipper when the chipper is being lifted up, lowered or moved about.
2. Never go below or climb onto the chipper which is being held up above ground supported on the tractor hitch without proper supporting stands.
3. Before starting up the chipper, make sure that it is correctly attached and that all safety shields are in place and properly fitted.
4. Always ensure before starting to operate the machine that not outsiders remain within the operational area.
5. Check the condition of the machine always at the end of a working shift. Pay special attention to the mounting and attachment points.



The noise level on the working site exceeds 85 db and for this reason always use hearing protectors.

4.2 TRANSPORTATION AND TRAFFIC RULES

1. Always comply with the highway when transporting the machine on public roads.
2. For transportation on public roads, always fit the chipper with any locally required safety accessories, such as additional rear lights, reflectors and SMV triangle.
3. Take care to note the allowed maximum axle weights, total weights and transporting dimensions of the combination.
4. All accessories and equipment used for moving the chipper (chains, drawbars, tie-rods etc.) must be attached and placed in such a way that any inadvertent movements cannot affect them in any manner when the machine is either operating or being transported.



4 SAFETY PRECAUTIONS



5. The manoeuvrability of the tractor during any transportation and its steering or braking characteristics may be affected adversely by trailed or hitchmounted implements or extra weights. It is therefore imperative to ensure that the tractor can be properly steered and braked down under all circumstances.
6. It is forbidden to carry passengers on top of a moving chipper.
7. The machine may be lifted only from points clearly marked for the attachment of a lifting hook.
8. Always use only approved lifting ropes or chains and always also check their condition before attempting a lifting operation.
9. If the machine is to be transported on a truck or a trailer bed, make sure to use proper straps or chains to tie the machine.
10. If a forklift or equivalent is used i.e. to load the machine on a truck, care must be taken to ensure that the machine is properly balanced and that there is no danger of its falling down on the ground.

4.3 MAINTENANCE AND REPAIRS

1. Before attempting any cleaning, lubrication, assembling or adjustment operations, always ensure first that the tractor PTO is disengaged and the engine stopped. Remove the ignition key from the starter switch to prevent any accidental starting up of the tractor or the implement.
2. Use suitable blocks to make the machine securely immovable before commencing any maintenance operations on the machine.

4.4 HYDRAULIC SYSTEM

1. After having coupled the chipper's hydraulic system to the tractor hydraulic system outlets and started the engine, the chipper hydraulic system is pressurized by the high tractor system pressure. A burst of high pressure oil will penetrate the skin and may cause grievous bodily harm. A risk of injury exists even when looking for possible oil leaks.
2. Take extra care when handling any hydraulic components. Due to their nature there exists a risk of skin cuts or getting fingers bruised between binding components.
3. When coupling the tractor and chipper hydraulic hoses together, the hydraulic systems of both units must be non-pressurized.

PROTECTING ONESELF AGAINST OIL AND GREASE

1. Always wear suitable protective clothing and oil resistant gloves when handling oil or grease.
2. Avoid skin contact with oil or grease as this may lead to skin damage.
3. Never use oil or grease for cleaning any part of your skin. These substances may contain minor metallic particles which may cause scratching of hands, further aggravated by the action of the oil.
4. Always comply with the handling and safety instructions given by the oil or lubricant manufacturer.
5. Synthetic oils tend to be corrosive in many cases and cause intense irritation of the skin.

WASTE OIL

1. Collect all of any used oil and take it to a hazardous waste disposal centre or collection point to be duly disposed of as required by national regulations.

ACCIDENTS

1. Should any oil be spilled on ground its spreading into the soil must be stopped and the oil removed e.g. by using peat to absorb the oil.
2. If any skin damage occurs while handling oil or lubricant call on a doctor immediately.



4 SAFETY PRECAUTIONS



4.5 UNIVERSAL DRIVE SHAFT

1. Shut down the tractor Pt.o. (power take-off) drive every time you leave the tractor cab.
2. Check that the universal drive shaft external, enveloping safety tubes do not rotate with the shaft inside. Attach the check chain with care.
3. When the machine is being transported on public roads, the driver must make sure that the Pt.o. power is cut off.
4. Before connecting the Pt.o. drive on, make sure that nobody is staying near the rotating Pt.o. shaft.
5. The universal drive shaft must be attached to the tractor Pt.o. only when the Pt.o. shaft is in neutral and not turning, the tractor engine stopped and the ignition key removed from the ignition switch.
6. When starting up the engine, the Pt.o. must be in the neutral position.
7. The tractor Pt.o. speed must correspond to the operating speed range of the machine's drive mechanism.
8. The limitations set for the Pt.o. speed must be fully observed, otherwise a too high a speed will damage the machine.
9. Move the Pt.o. drive into neutral position every time when it is not needed to drive an implement or when the tractor and the implement are turning through a very steep articulation angle.
10. Before connecting the drive to the Pt.o. shaft, and while it is rotating, make sure that no persons are staying within the danger area of the rotating drive shaft.
11. Do not use other than CE labelled drive shafts, approved by the wagon manufacturer. All Pt.o. safety guards, shields and the tractor Pt.o. guard must be in place and in proper condition.
12. Never use a damaged drive shaft because of the grave danger its use poses. A damaged shaft must be repaired before it is used in the Pt.o. drive.
13. Observe the lengths of the drive shaft telescoping outer and inner shield tubes both in transport and in working positions.
14. After having shortened the drive shaft, the splined ends must be cleaned and the lubrication grease applied to the splines thoroughly.
15. When the universal drive shaft is either being attached to or detached from a tractor, the tractor Pt.o. must be in neutral position. Never use the tractor clutch for disengaging transmission drive to the Pt.o. gears momentarily in order to stop the Pt.o. shaft from rotating.
16. After having attached the drive shaft, its securing peg must engage in the locking position in the shaft groove. Check that the shaft is positively secured in its place.
17. Attach the drive shaft shield securing chain so that the shield cannot rotate.
18. When not in use, store the drive shaft on suitable supports.



NOTE THAT THE MACHINE IS MEANT TO BE OPERATED BY A COMPETENT OPERATOR. THUS, THE USE OF THE MACHINE REQUIRES SUFFICIENT KNOWLEDGE AND SKILL.





5. SAFETY DECALS AND COMPONENTS AND SERIAL NUMBER PLATE



5.1 SERIAL NUMBER PLATE

SERIAL NUMBER PLATE

1. Manufacturing year within the EC
2. Machine model
3. Serial number and year model
4. Nominal weight without accessories
5. Name of the CE plate installer

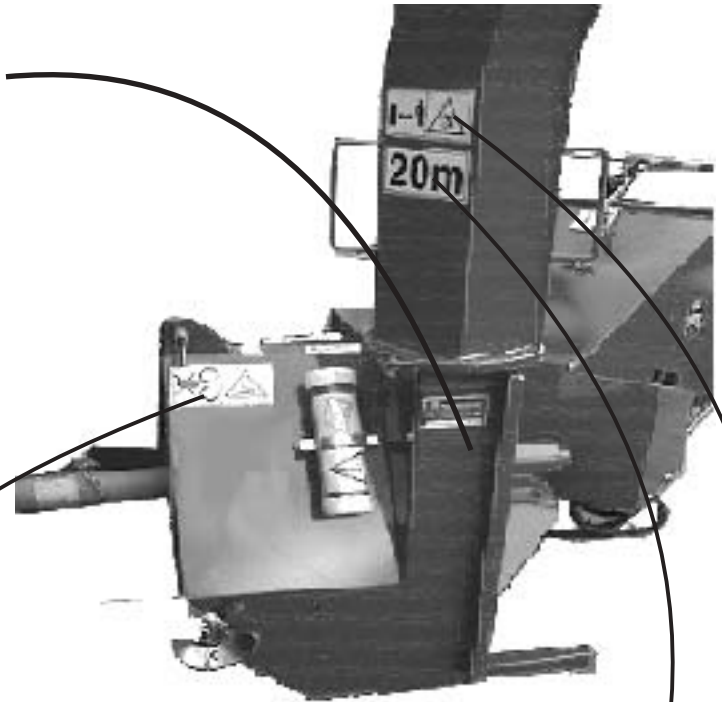
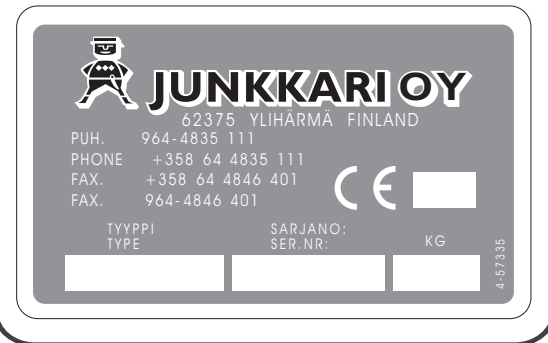

5.2 SAFETY DECALS

BEWARE UNIVERSAL SHAFT

THE AREA OF DANGER IS 20m FOR SPRAYING DIRECTION



5. SAFETY DECALS AND COMPONENTS AND SERIAL NUMBER PLATE

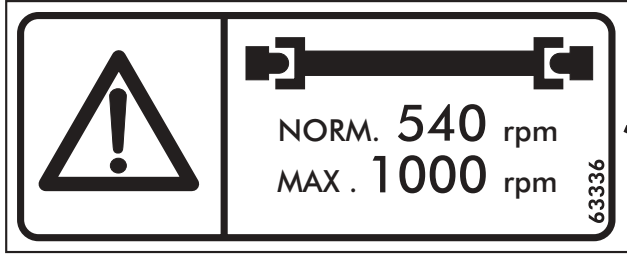



MAX. ROUNDING SPEED

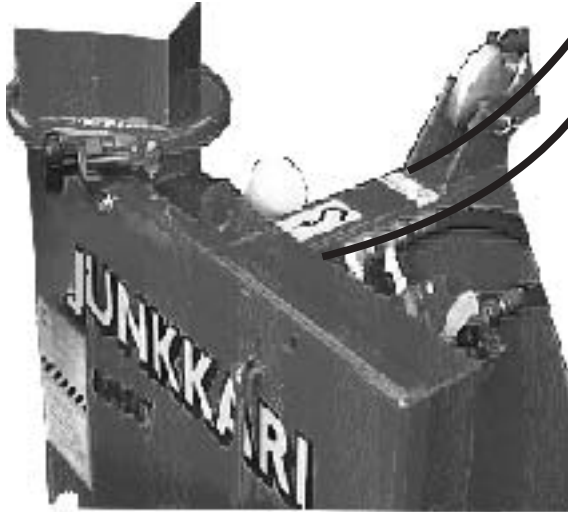

LIFTING BRACKET

USE EAR PROTECTORS





VAROITUS !
VARO liikkuvia osia !
PYSÄYTÄ kone ryhtyessäsi huolto- tai korjaustyöhön!
PIDÄ lapset poissa koneen luota!

WARNING!
WARNING för rörliga delar!
STANNA maskinen vid service- eller reparationsarbeten!
HÅLL barnen borta från maskinen!

WARNING !
BE CAREFUL with moving parts!
STOP the machine when repairing or making service!
TAKE CARE OF that children are not near the machine!

ATTENTION!
Ne pas approcher des pieces en mouvement!

VORSICHT !
Seien Sie vorsichtig mit beweglichen Teilen !
Stoppen Sie die Maschine während der Reparatur-und
Wartungsarbeiten !
Sorgen Sie dafür, daß Kinder sich nicht in der Nähe der
Maschine aufhalten !

4-8749



EMERGENCY STOP

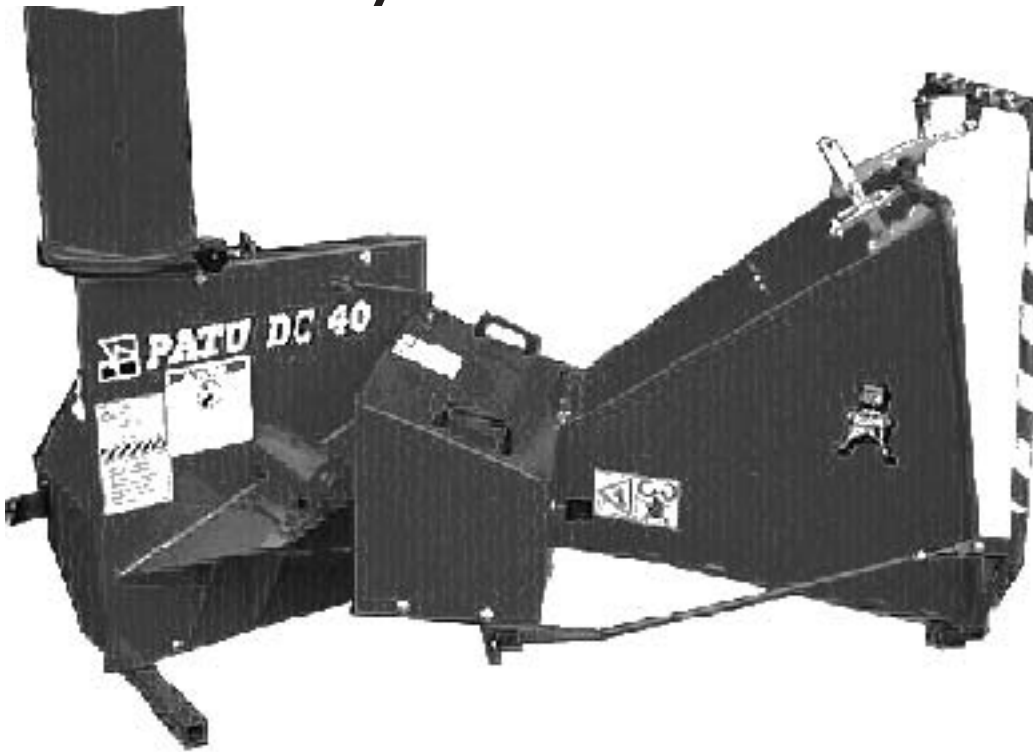
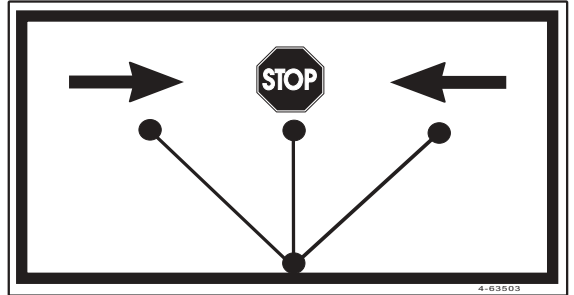

WARNING FEED ROLLERS

ÄLÄ AVAA SUOJIA
KONEEN KÄYDESSÄ!

ÖPPNA EJ SKYDD NÄR
MASKINEN ÄR I GÅNG!

DON'T OPEN THE COVER
WHEN THE MACHINE IS
RUNNING!



6. OPERATING ENVIRONMENT

6.1 OBJECT OF USAGE

The purpose of a chipper is to produce chips from trees, which due to their diameter and other measurements are suitable for feeding into the chipper's feed orifice. The in-fed material must be clean. Dust, sand or soil ingredients accelerate wear on the knives very quickly. Metal bits, nails e.g., cause denting of the knives. Any large metal pieces may severely damage the chipper.

6.2 APPLICATIONS

If the chipper is intended to be used for chipping down card-board rolls, plastic piping or hard boarding panels, please contact your dealer before commencing this kind of activity.



6.3 LIMITATIONS OF USE AND PROHIBITED FORMS OF USE !



LIMITATIONS OF USE

- *Limitations regarding the machine operator*

The machine operator must not be under the influence of intoxicating substances, alcohol or strong medication.

In cases of ill health or permanent disability the doctor in charge should be consulted for permission to operate the machine.

Use of the chipper is prohibited for persons without the sufficient knowledge and skill required to operate the machine and for persons under the age of 18 years.

- *Prohibited forms of use*

The chipper must not be used within any areas reserved for the conservation of nature.

The machine must not be used for spreading liquids, inflammable materials, sand or equivalent non-fibrous materials.

Avoid using the machine in areas where its use could cause inconvenience to its surroundings due to excessive noise or spreading of dust.

Chipping of highly inflammable materials is absolutely forbidden.

7 PRINCIPLE OF OPERATION

A chipper model not fitted with a feed mechanism operates on the principle that, while chipping the stem or other wood material, the chipping knives mounted on the rotating chipping flange draw in the material automatically. The feeding speed depends on the knife setting as follows: A short knife setting results in a small chip size and a slow intake speed - a wide knife setting results in a large chip size and consequently in a high intake speed. The chips produced by the action of the knives are ejected through the knife flange orifices to the blower fan and out of the machine through the discharge spout.

In chipper models, which are equipped with a feed mechanism, the intake of material is power-assisted by a set of feed rollers driven by hydraulic motors. The motors in turn are driven by pressurized oil either from the tractor hydraulic system or a self-contained, independent hydraulic system via a control valve. The feed control lever has 3 positions: Feed, stop and reverse.

8 TRANSPORTATION, HANDLING AND STORAGE

(DISTRIBUTOR/DEALER)

8.1 TRANSPORTATION

1. Terms of delivery is free at the factory gate unless other terms are mutually agreed upon.
2. The Distributor shall agree with the Manufacturer on the date upon which the product in question is ready for delivery at the factory.
3. The Manufacturer shall take care of the loading of the product onto the goods vehicle arranged to fetch the product.
4. For the duration of transportation from the factory to the Distributor's premises all responsibility of the product shall lie with the forwarding agent.

8.2 HANDLING

1. The product must be handled with such care as is normal when handling agricultural or forestry machinery without causing the product any damage.
2. No other products may be loaded on top of the machine transportation crate.
3. The product is delivered well-packed from the factory.

8.3 STORAGE

1. The chipper is to be stored in its normal working position and protected against sunlight and rain.
2. Should the machine be left standing outdoors for any period of time without proper protection, it should be inspected from time to time and any rainwater accumulated on top of the machine drained away.
3. For long periods of storage always store the machine indoors under shelter.



8.4 SPECIFIC NOTES ON TRANSPORTATION SAFETY



1. It is prohibited to lift the machine from any other points than those clearly marked for lifting by decals.
2. Make certain that the crane or equivalent used for the lift has sufficient capacity and is safe enough for the job and that no risk of overturning or falling down occurs.
3. Use only approved ropes or chains for lifting.
4. The chipper must not be lifted up resting on the forks of a fork lift truck, only ropes or chains are suitable for any lifting operations.
5. Always check the condition of lifting ropes or chains prior to any lifting attempt.
6. If during a lifting operation the machine is to be laid down resting on its side or lifted up to rest on its wheels the lifting ropes or chains must be kept tight to prevent any accidental swaying of the machine in order to avoid dangerous situations.
7. If using a lifting crane, always check the lifting radius.
8. The chipper must be securely tied down to the platform for the duration of transportation.

9. TAKING A NEW MACHINE INTO USE

9.1 PREPARATIONS PRIOR TO OPERATING

A new machine must be brought into a proper operating condition by the operator prior to the machine's first use. If the chipper is delivered with its discharge spout independently packed, the attach the spout to the machine as follows: Place the spout on its mountings in such a manner that the guide lug on the spout lines up with recess in the mounting adaptor. Secure the spout in its place by means of the enclosed split clamp and its knurled nut. Turn the nut until it is tight.

When taking the chipper into use make sure that all the safety panels are in place, that no foreign matter is left inside the feed orifice and that the disc rotates freely. Before connecting the machine and its drive to the tractor check the instruction manual notes on the PTO shaft and proceed accordingly. Only after observing these points may the chipper be coupled to the tractor.

9.2 DISCARDING PACKAGING MATERIALS

The wooden and cardboard packaging materials may be disposed of by burning or taking them to a dump site. The polyethylene bags and plastic cords should be disposed of either by recycling them according to national regulations or by taking them to a dump site.

9.3 ATTACHMENT TO A TRACTOR

The chipper is designed for attachment to tractors equipped with category 1 or 2 lower links (i.e. either with 22 or 28 mm attachment pins).

In the delivery condition the chipper's mounting links have been raised into vertical positions. They must be lowered down and secured in the position as shown in the accompanying figure on the right. The length of the mounting links can be adjusted by the set of alternative attachment holes in the links.

The tractor lower links and the top link are attached to the chipper mounting points in the normal manner and the lower links secured in their centre position by means of their stabiliser.

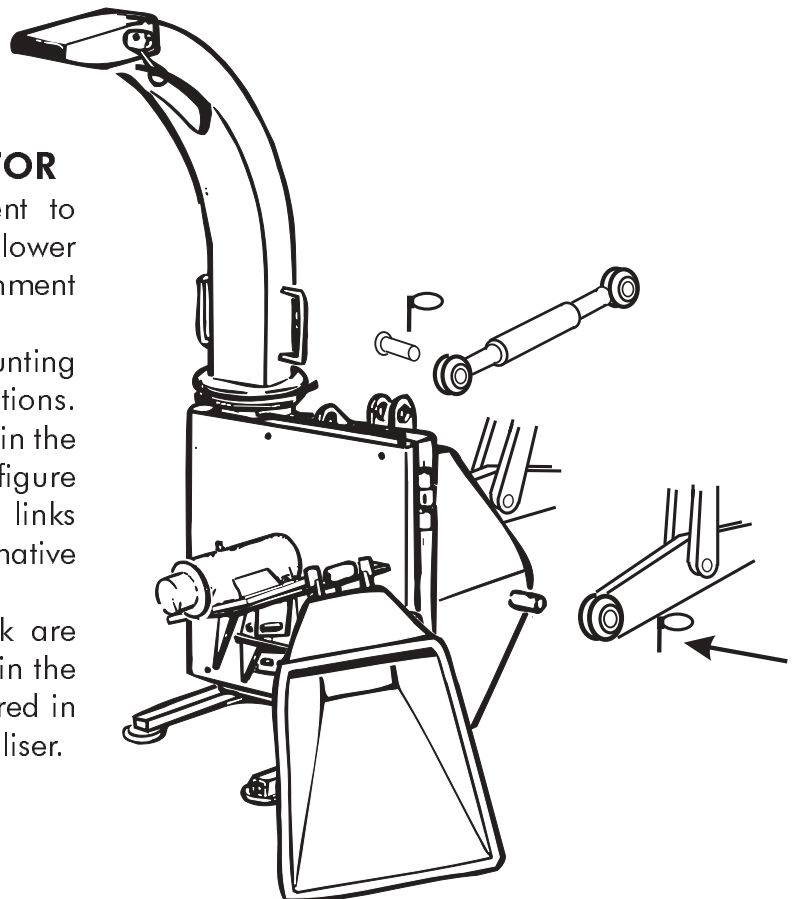

TRACTOR PTO

The starting of the chipper should be made smoothly on low rpm due to the large rotating masses inside the chipper. During operation, the chipper cutting flange speed must be kept within the range of 540-1000 r.p.m. The universal drive shaft has been discussed separately in the chapter titled "PTO SHAFT".



9.4 PTO SHAFT



TYPE OF PTO SHAFT

The universal drive shaft should have the capacity of transmitting power at a rate of 35 kW at a nominal speed of 540 rpm and to sustain a torque of 620Nm. The shaft should be fitted with an overload clutch. A suitable drive shaft is, for example, EG 50 080 F112 F.12 overrunning, or Walterscheid 2200 080 F112 B.02.

PTO SHAFT LENGTH

The drive shaft must be of correct length for the application for the sake of operator safety, the mechanical durability of the shaft itself and its operational characteristics. The splines of the sliding tubes must overlap at least by 100 mm (4"). Too long a shaft will bottom causing the shaft to get damaged. With too short a shaft the two halves may get separated from each other when lifting the implement on the tractor hitch. This could lead even to grave consequences.

Too small an overlap also reduces the shaft's capacity to transmit the required power and thus may lead to mechanical damage to the shaft itself.

SHORTENING A PTO SHAFT

1. The shortest operational length of the shaft is determined by lifting the machine on the tractor hitch (see Fig.1).
2. A 25 mm (1") free play should be left on the shaft and marked on the shaft circumference (see Fig.2).
3. Using a hacksaw, saw off equal lengths from inner and outer tubes and shields of both shaft halves (see Fig.3).
4. Remove cutting burns with a file and make clean all tubes.
5. Grease the shaft tubes thoroughly before fitting the shaft in place.

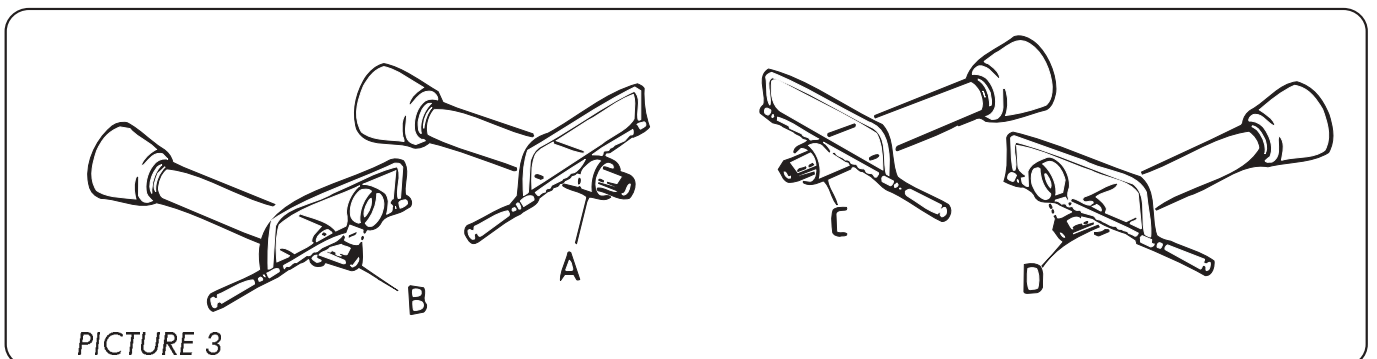
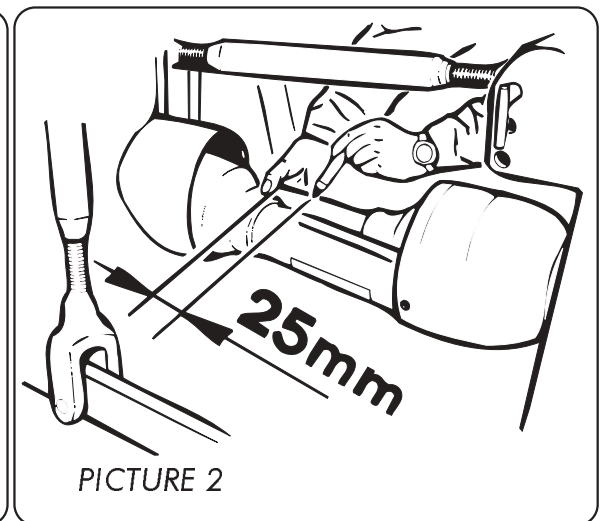
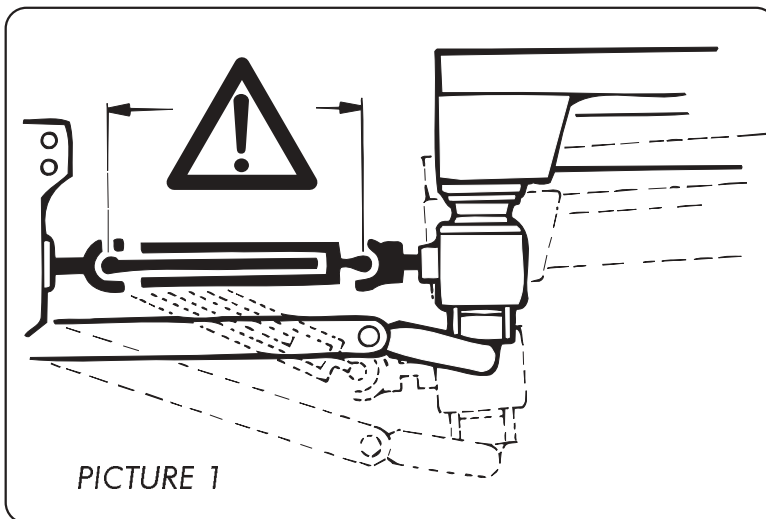

10 ADJUSTMENTS

PLEASE READ THESE INSTRUCTIONS VERY CAREFULLY AS THE MOST IMPORTANT POINT IN THE OPERATION OF THE CHIPPER IS THE CONDITION OF THE KNIVES AND THEIR CORRECT ADJUSTMENT.

10.1 ADJUSTMENT OF KNIFE SETTINGS

The knife setting may be adjusted within the range of 4 to 12 mm. The smaller the setting, the smaller the chips the chipper produces. On the other hand, the knife setting affects the intake speed in the manner that a larger knife setting results in a faster and better intake of material.

Before opening flywheel access door:

Disconnect clutch and PTO shaft from chipper axle, then re-connect chipper to tree-point tractor hitch, only then, remove 4 bolts and open flywheel door.



WARNING:

If chipper is not attached to tractor, it will fall over when door is opened.

To adjust, loosen the knife attaching screws (2 ea) and the locking screws (2 for each knife). Open the bed knife attaching screws and pull out both bed knives towards the feed chute. Move one cutting knife into a required position on the disc (measurement 'A'). Tighten down both the attaching and locking screws of the knife in question. Move the bed knives correspondingly to leave a free gap of 1 mm (measurement 'B') between the knife and the bed knife. Tighten down the counter-blade attaching screws. Proceed to adjust the remaining 3 cutting knives bringing each one in turn to the adjusted bed knife and adjusting each knife to leave the 1 mm gap ('B') between each knife and the bed knife. Finally tighten down all knife and bed knife attaching screws to a tightness of 20 kpm (145 lbft). Rotate the disc by hand to ensure that the cutting knives do not make contact with the bed knives and that the gap ('B') between the knives and bed knives equal (1 mm) for each cutting knife. Finally, tighten down the cutting knife locking screws against the rear edge of each knife to a 5 kpm (36 lbft) tightness.

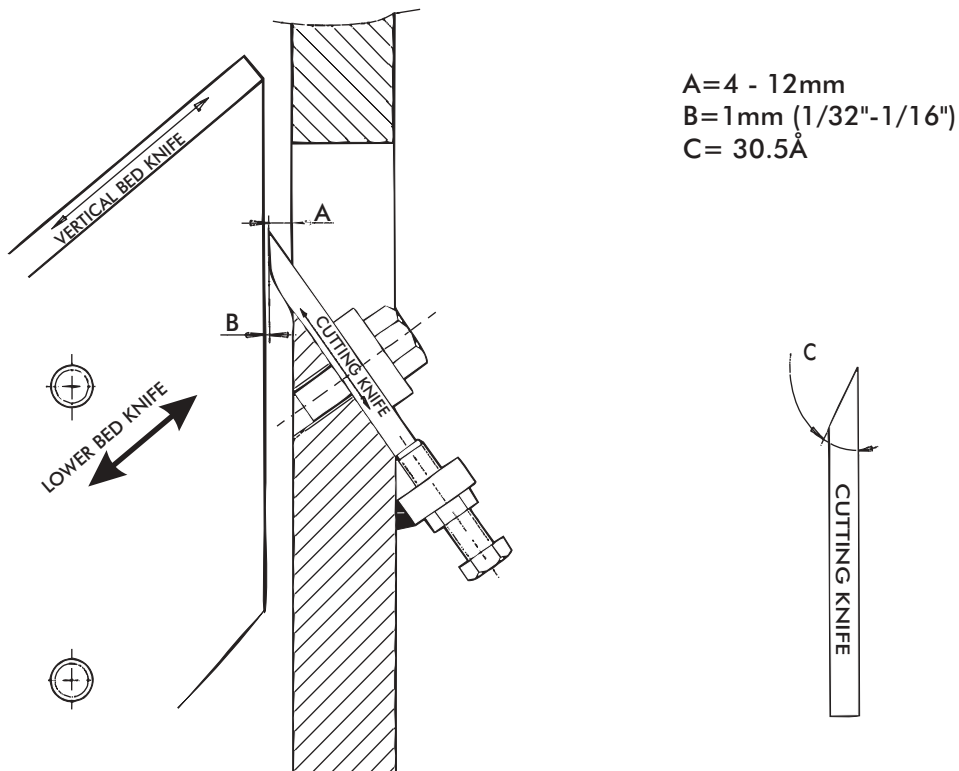

10.2 FEED RATE ADJUSTMENT

The rotational speed of the feed rollers in chipper model HJ4 SLT must be synchronized with the cutting speed of the cutting knives. If the feed roller rpm is too high in relation to the knife cutting speed, the roller tend to dig into the stems being fed in. If the feed roller speed has been set too slow, the feed becomes jerky.

The adjustment is to be started with low feed roller rpm. At this stage, the cutting knives tend to pull out the stem from between the feed rollers. The feed mechanism speed is then slowly increased until it synchronizes with the cutting knife setting in use and the feed remains smooth.

ADJUSTMENT

The feed speed adjustment is carried out by first loosening the locknut 'A' and moving the adjusting lever 'B' to the end of the adjustment range. A stem is the fed into the chipper for chipping down and the potential variation between the speeds of the feed mechanism and the cutting knife action is observed. If the feeding speed is too slow, increase the speed by moving the adjustment lever towards the fast end of the range. Repeat the adjustment as necessary. When the synchronization is correct, screw in the locking nut 'A' tightly.

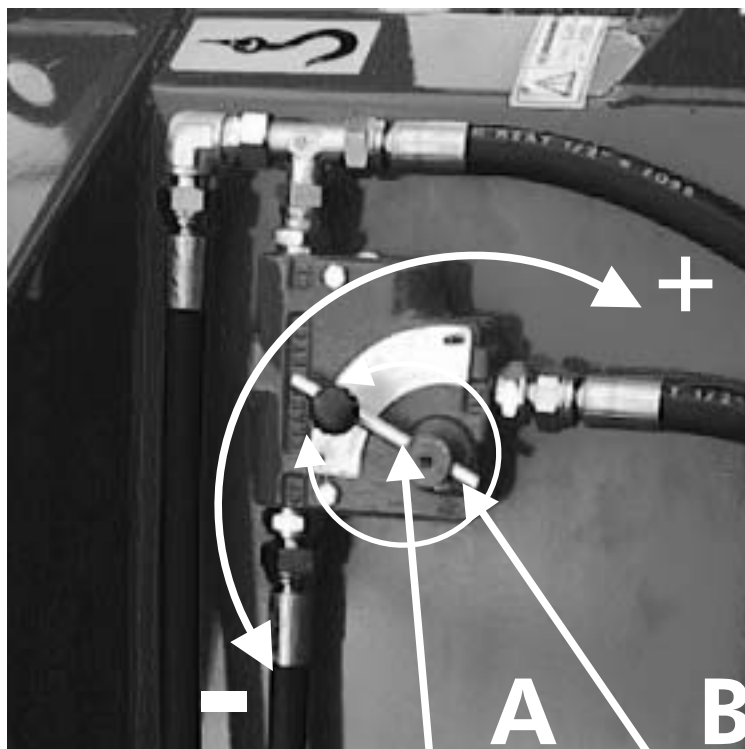

11. USAGE

The HJ4 chipper is primarily designed for handfeeding. The material to be chipped should, when need arises, be first pre-treated so that all heavy tree branches or off-shooting main roots etc. should be removed in order to adapt the stem into the dimensions of the feeding orifice.

It is a recommended practice to arrange the material alongside the chipper in such a way that there is little need to carry any of it over other than the minimum distances. In this way the working efficiency remains as high as possible and additionally a solid flow of material will produce the best quality chips.

12 MAINTENANCE



READ THE SAFETY INSTRUCTIONS CAREFULLY



12.1 SHARPENING THE CUTTING KNIVES

The cutting angle of factory-new cutting knives is 30.5° . This is the optimum angle which should always be used when re-sharpening the knives. A smaller angle will result in chipping in the knife edges, while a greater angle will reduce the knife edge's clearing angle causing a reduction in the ability of the knives to draw in the material.

Note that the cutting knives must not be allowed to heat up during the sharpening process as the knives will otherwise lose the hardness acquired by their heat-treatment. The knives should therefore be sharpened solely by grinding. When grinding, care should also be taken to sharpen all knives by equal amounts, so that the overall balance of the knife flange is retained.

As a rule, there is normally no need to sharpen the bed knives. Their cutting edges may, however, be rounded off if the intaken material includes substances that are harder than wood (nails, sand etc.). A blunted bed knife can be re-sharpened with e.g. an electric hand-grinding machine. In the main, the bed knives should remain maintenance-free.



12.2 LUBRICATION

Following lubrication operations should be carried out at the intervals of the cumulative operating hours given in the tables.

Disc shaft bearings (2 ea):

Fill in with lubricating grease	50 h
Feed mechanism bearing (1 ea)	50 h

13. FAULT FINDING CHART

FAULT	CAUSE	REMEDY
The chipper does not draw in material	Dull knives Knife cutting angle faulty Knife fitted the wrong way round	Sharpen and refit as per instructions given in the manual
Uneven chip size	Knife gap ('B') too large	Adjust as per instructions given in the manual
The discharge spout gets blocked	Too low rpm	Raise the rpm to within the speed range of 540-1000 rpm
Power requirement excessive on the tractor	Tractor hp too small Knife setting too large ('A')	Reduce the cutting knife setting or remove the opposite blades
Feed rollers powerless	Hydr. Pump drive Belts loose. Pump suction Hose leaky. System oil level too low.	Tighten the belts as per instructions in the manual.
Ingoing material produces excessive vibrations.	Feed rollers not properly synchronized.	See the notes on synchronization of the feed rollers.

13.1 DEVELOPMENT OF FAULTS

The normal wear taking place in the chipper proceeds in a safe fashion without producing any risks of danger. In practice, the only wearing chipper parts are the cutting knives. Should a situation occur where excessive bearing play is observed, the adjustment of such a condition should be left to be remedied by a competent fitter.

14 TERMS OF WARRANTY

TERMS OF WARRANTY:

1. The manufacturer warrants the product for a period of 12 (twelve) months in agricultural use and used in the purpose to which the product is intended.
2. In communal, industrial, contract work or equivalent the warranty period is 6 (six) months.
3. The warranty period commences on the date an authorized Distributor/Dealer delivers a new machine to the customer.
4. The warranty covers any defects in workmanship or in raw materials. The faulty parts shall be renewed or replaced by reconditioned parts either at the factory or at the premises of an authorized repair shop in contractual relation with the factory.
In the case of subcontracted components, the warranty will be covered by the terms given by the suppliers of such products.
5. A warranty repair does not prolong the length of the warranty period.
6. The warranty does not apply in cases, where the damage has been caused by improper use of the product against the instructions given in this operator's manual or arising from negligent maintenance, overloading or normal wear. Further the warranty does not apply to any subsequential damages caused by the original failure nor cover any costs occurred by downtime, travelling expenses, freights, daily allowances, overtime or any modifications, which alter the original design in any way.

In warranty-related cases please contact your Distributor/Dealer for preparing a warranty claim on the failure. Before taking any corrective action to repair the fault, the manufacturer must be contacted to assess the repair method and the costs occurring thereof.

The Warranty is only applicable if the properly warranty certificate is returned to the manufacturer within 14 (fourteen) days from the date of delivery of the product.

15. SCOPE (EXTENT) OF RESPONSIBILITY

The manufacturer shall not be responsible for any consequences arising from the use of the product (Patu Chipper) in a manner contrary to law, safety regulations or instructions out-laid in this manual. As situations may occur during the use of the product not foreseen in instructions or regulations, the operators are advised to act according to general safety regulations and directives on (farm) machinery.

The manufacturer shall not be liable for any damages due to the use of components produced by other manufacturers.

The manufacturer shall not be responsible for any damages which may incur other machinery or equipment from the use of the chipper.