



Performance

Angles très importants = Performances améliorées



- ✓ angle de bennage plus important
- ✓ butée de bennage active
- ✓ moins de perte de capacité de levée du sol à hauteur maximum

	cavage au sol	bennage hauteur à maxi.
Q930	41°	53°
Q45	43°	59°

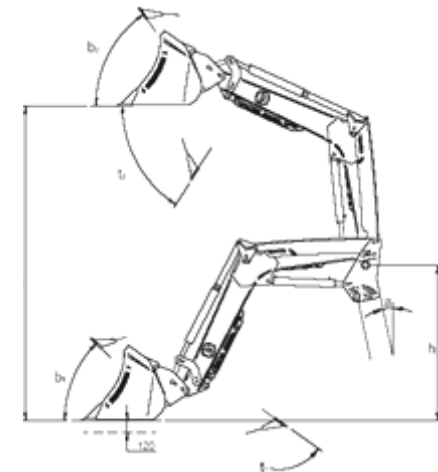



Angles plus large – amélioration de mouvement

	relevement	vidage
Q930	41°	53°
Q45	43°	59°



- ✓ Angle de vidage plus grand
- ✓ Vidage rapide "stop" sécurité
- ✓ moins de perte de capacité de levage du sol à hauteur maxi

